

THE ITALIAN LIFESTYLE

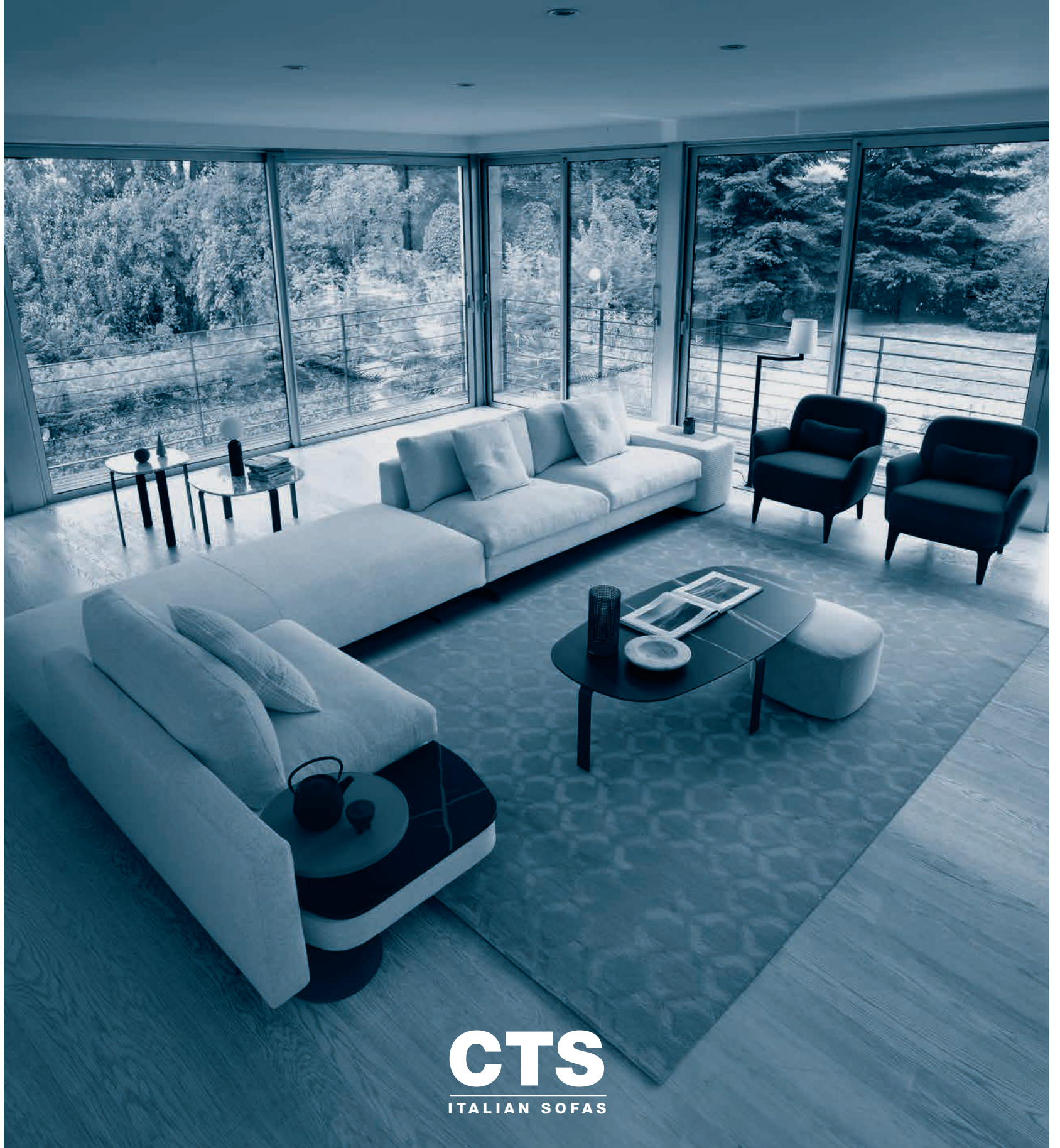

CTS
ITALIAN SOFAS

THE ITALIAN LIFESTYLE

CTS
ITALIAN SOFAS

SOFA

IKON 01 PAG.10



IKON 02 PAG.16



IKON 03 PAG.18



SOFA

IKON 04 PAG.20
MONOBLOCCO



IKON 05 PAG.26



SOFA

IKON 06 PAG.30
MONOBLOCCO



DORMEUSE

IKON PAG.34
MONOBLOCCO



SOFA

IKON 07 PAG.36



SOFA

CREO PAG.42



SOFA

TIME 01 PAG.44



TIME 02 PAG.48



SOFA

FLAP LARGE PAG.50



INDEX

SOFA

ROGER 01 PAG.56



ROGER 02 PAG.58



SOFA

ELLIOT PAG.62



CHAISE LONGUE

ELLIOT PAG.60



ARMCHAIR

GRACE PAG.64



VANITY PAG.66



JACK PAG.68



ARMCHAIR

MARGOT PAG.70



PLAZA PAG.72



GUEST PAG.74



INDEX

CHAIR

ARIEL PAG.84



COFFEE TABLE

FOR YOU PAG.78



ALLURE PAG.76



COFFEE TABLE

TAPE PAG.82



CHARME PAG.62



POUFF

BRERA PAG.80



DOMINO PAG.72





THE ITALIAN LIFESTYLE

CTS SALOTTI È UN'AZIENDA CREATIVA SPECIALIZZATA NELLA PRODUZIONE DI IMBOTTITI, DOVE IL DESIGN E LA COMODITÀ SONO VALORI IMPRESCINDIBILI CHE RENDONO OGNI PRODOTTO UNICO E PREZIOSO.

DA OLTRE 55 ANNI I DIVANI NASCONO DALLA PASSIONE E DALLA SARTORIALITÀ, DA UN EQUILIBRIO PERFETTO TRA AVANGUARDIA E TRADIZIONE, DA UNA MANUALITÀ SOLO IN PARTE AIUTATA DALLA TECNOLOGIA.

TUTTA LA PRODUZIONE E I CONTROLLI QUALITATIVI, VENGONO EFFETTUATI DA PERSONALE ALTAMENTE QUALIFICATO; OGNI FASE DELLE LAVORAZIONI, DAL TAGLIO AL CUCITO FINO ALLA CONFEZIONE, VENGONO ESEGUITE CON GRANDE CURA E ATTENZIONE.

È IL SAPER FARE ITALIANO CHE CONTRADDISTINGUE CTS SALOTTI NELLE SCELTE ESTETICHE, È IL SEGNO DISTINTIVO E IL DESIDERIO DI AFFERMARE LE NOSTRE RADICI CULTURALI.

CTS SALOTTI IS A CREATIVE COMPANY SPECIALISING IN SOFT FURNISHINGS IN WHICH DESIGN AND COMFORT ARE ESSENTIAL VALUES THAT MAKE EVERY PRODUCT EXQUISITE AND UNIQUE.

FOR OVER 55 YEARS OUR SOFAS HAVE BEEN MADE WITH PASSION AND IMMACULATE TAILORING, A PERFECT BALANCE OF MODERNITY AND TRADITION, AND MANUAL WORK ONLY PARTIALLY AIDED BY TECHNOLOGY.

ALL OUR PRODUCTION PROCESSES AND QUALITY CHECKS ARE CARRIED OUT BY HIGHLY QUALIFIED STAFF; EVERY STAGE OF THE PROCESS, FROM CUTTING TO SEWING AND ASSEMBLY, IS DONE WITH ENORMOUS CARE AND ATTENTION.

IT IS ITALIAN SAVOIR FAIRE THAT DISTINGUISHES CTS SALOTTI'S AESTHETIC CHOICES: AN IDENTIFYING SIGN AND A DESIRE TO REAFFIRM OUR CULTURAL ROOTS.

CTS
ITALIAN SOFAS



IKON 01

SOFA

Design Marconato&Zappa
Cm. 243x465x81 h.

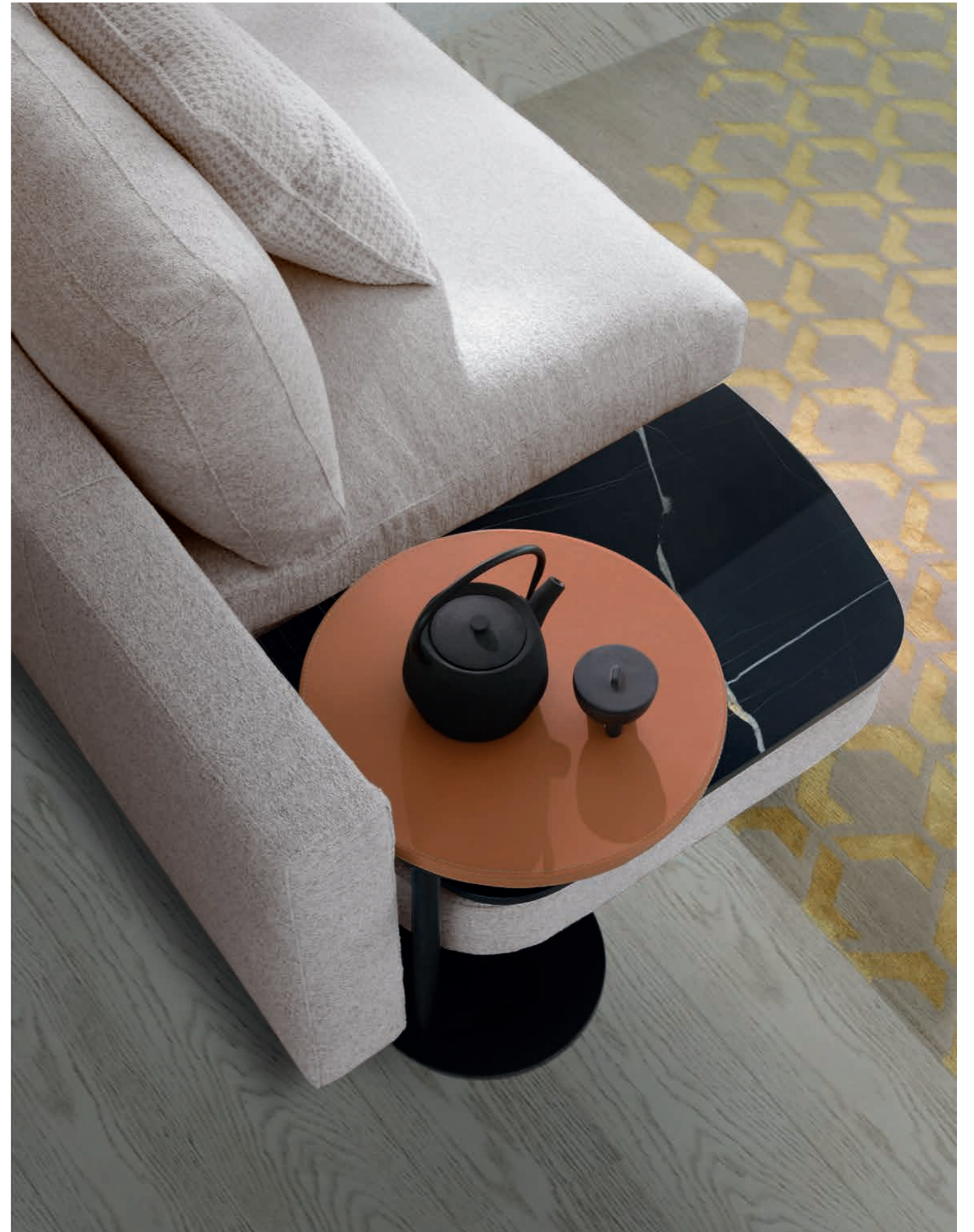

IKON 01

SOFA

Design Marconato&Zappa
Cm. 243x465x81 h.

ECLETTISMO GLAM RELAXED PER IL DIVANO IKON DALLE FORME ESCLUSIVE, CARATTERIZZATO DA UNA PROPOSTA CHE VALORIZZA LO SPAZIO DOMESTICO. UN DESIGN RAFFINATO E DI FORTE PRESENZA SCENICA.

RELAXED, ECLECTIC GLAMOUR FOR THE EXCLUSIVE-DESIGN IKON SOFA, A PRODUCT TO ENHANCE YOUR LIVING SPACE. SOPHISTICATED DESIGN AND STRONG SCENIC PRESENCE.



DIVANO IKON, POLTRONE MARGOT, TAVOLINI ALLURE, POUFF BRERA.
IKON SOFA, MARGOT ARMCHAIRS, ALLURE COFFEE TABLES, BRERA POUF.

IKON 01

SOFA

Design Marconato&Zappa
Cm. 243x465x81 h.



DIVANO IKON, POLTRONE MARGOT, TAVOLINI ALLURE, TAVOLINO FOR YOU, POUFF BRERA.
IKON SOFA, MARGOT ARMCHAIRS, ALLURE COFFEE TABLES, FOR YOU COFFEE TABLES, BRERA POUF.

IKON 02

SOFA

Design Marconato&Zappa
Cm. 192x96x81 h.



DIVANO IKON, TAVOLINI ALLURE, POUFF BRERA.
IKON SOFA, ALLURE COFFEE TABLES, POUFF BRERA.

IKON 03

SOFA

Design Marconato&Zappa
Cm. 392x96x81 h.

DIVANO IKON, POLTRONE MARGOT, TAVOLINI ALLURE, TAVOLINO FOR YOU, POUFF BRERA.
IKON SOFA, MARGOT ARMCHAIRS, ALLURE COFFEE TABLES, FOR YOU COFFEE TABLES, BRERA POUF.



IKON 04 MONOBLOCCO

SOFA

Design Marconato&Zappa
Cm. 294x96x81 h.



IKON 04 MONOBLOCCO

SOFA

Design Marconato&Zappa
Cm. 294x96x81 h.



DIVANO IKON, POLTRONA PLAZA, TAVOLINI ALLURE, TAVOLINO FOR YOU, POUFF BRERA.
IKON SOFA, PLAZA ARMCHAIRS, ALLURE COFFEE TABLES, FOR YOU COFFEE TABLES, BRERA POUF.

FOR YOU

COFFEE TABLE

Design Marconato&Zappa
Cm. ø42,5x47 h.



IKON 05

SOFA

Design Marconato&Zappa
Cm. 390x162x81 h.



DIVANO IKON, POLTRONE GUEST, TAVOLINI ALLURE, TAVOLINO FOR YOU, POUFF BRERA.
IKON SOFA, GUEST ARMCHAIR, ALLURE COFFEE TABLES, FOR YOU COFFEE TABLE, BRERA POUF.



IKON 05

SOFA

Design Marconato&Zappa
Cm. 390x162x81 h.

“L'ELEGANZA NON È FARSI NOTARE,
MA FARSI RICORDARE.”

“ELEGANCE ISN'T BEING NOTICED,
IT'S BEING REMEMBERED”.

(Giorgio Armani)



DIVANO IKON, POLTRONE GUEST, TAVOLINI ALLURE, TAVOLINO FOR YOU, POUFF BREFA.
IKON SOFA, GUEST ARMCHAIR, ALLURE COFFEE TABLES, FOR YOU COFFEE TABLE, BREFA POUF.

IKON 06 MONOBLOCCO

SOFA

Design Marconato&Zappa
Cm.224x96x81 h.



DIVANO IKON, DORMEUSE IKON, TAVOLINI ALLURE.
IKON SOFA, IKON DORMEUSE, ALLURE COFFEE TABLES.



IKON 06 MONOBLOCCO

SOFA

Design Marconato&Zappa
Cm.224x96x81 h.



DIVANO IKON, DORMEUSE IKON, POLTRONA JACK, TAVOLINI ALLURE, POUFF BRERA.
IKON SOFA, IKON DORMEUSE, JACK ARMCHAIR, ALLURE COFFEE TABLES, BRERA POUF.

IKON MONOBLOCCO

DORMEUSE

Design Marconato&Zappa
Cm. 225x100x42 h.



IKON 07

SOFA

Design Marconato&Zappa
Cm.308x212x81 h.



IKON 07

SOFA

Design Marconato&Zappa
Cm. 308x212x81 h.

UNO SPIRITO LIBERO CARATTERIZZA IL PROGETTO IKON, UN SISTEMA DI SEDUTE COMPOSTE DA MORBIDI IMBOTTITI E COMPLEMENTI, CARATTERIZZATI DALLA MASSIMA LIBERTÀ DI COMPOSIZIONE.

A FREE SPIRIT, THIS IS THE IKON, A SEATING SYSTEM CONSISTING OF SOFT FURNISHINGS AND ACCESSORIES WITH MAXIMUM FREEDOM OF COMPOSITION.



DIVANO IKON, POLTRONE GRACE, TAVOLINO TAPE, TAVOLINO FOR YOU, POUFF BRERA.
IKON SOFA, GRACE ARMCHAIRS, TAPE COFFEE TABLE, FOR YOU COFFEE TABLE, BRERA POUF.

IKON 07

SOFA

Design Marconato&Zappa
Cm. 308x212x81 h.



DIVANO IKON, POLTRONE GRACE, POLTRONCINE ARIEL, TAVOLINO TAPE, TAVOLINO FOR YOU, POUFF BRERA.
IKON SOFA, GRACE ARMCHAIRS, ARIEL SMALL ARMCHAIR, TAPE COFFEE TABLE, FOR YOU COFFEE TABLE, BRERA POUF.

CREO

SOFA

Design Marconato&Zappa
Cm. 288x102x78 h.

“L'ARMONIA NASCOSTA VALE
PIÙ DI QUELLA CHE APPARE.”

“HARMONY THAT'S HIDDEN IS BETTER
THAN HARMONY THAT'S VISIBLE”.

(Eraclito)

TIME 01

SOFA

Design Marconato&Zappa
Cm. 331x182x78 h.



DIVANO TIME, POLTRONA JACK, TAVOLINI TAPE.
TIME SOFA, JACK ARMCHAIR, TAPE COFFEE TABLES.

TIME 01

SOFA

Design Marconato&Zappa
Cm. 331x182x78 h.



DIVANO TIME, POLTRONA JACK, TAVOLINI TAPE.
TIME SOFA, JACK ARMCHAIR, TAPE COFFEE TABLE.

TIME 02

SOFA

Design Marconato&Zappa
Cm. 248x102x78 h.

TIME, UN DIVANO ESSENZIALE CHE CONIUGA LA CLASSICITÀ DELLE FORME AL GUSTO CONTEMPORANEO DELLO SLOW LIVING: LINEE MORBIDE CHE DANNO ALLA CASA LUMINOSITÀ E CALORE.

TIME IS A MINIMALIST SOFA THAT COMBINES CLASSIC LINES WITH A CONTEMPORARY TASTE FOR SLOW LIVING: SMOOTH SHAPES THAT BRING WARMTH AND LIGHT INTO THE HOME.



DIVANO TIME, TAVOLINO CHARME.
TIME SOFA, CHARME COFFEE TABLE.

FLAP LARGE

SOFA

Design Marconato&Zappa
Cm.326x182x74/90 h.



FLAP LARGE

SOFA

Design Marconato&Zappa
Cm.326x182x74/90 h.



DIVANO FLAP LARGE, POLTRONA VANITY, TAVOLINO ALLURE, POUFF BRERA.
FLAP LARGE SOFA, VANITY ARMCHAIR, ALLURE COFFEE TABLE, BRERA POUF.



ROGER 01

SOFA

Design Marconato&Zappa
Cm.327x172x85 h.



ROGER 02

BEDSOFA

Design Marconato&Zappa
Cm. 229x106x85 h.



ROGER, UN DIVANO LETTO TUTTO DA "VIVERE" CON IL SUO DESIGN SENZA TEMPO. ESTREMA COMODITÀ ANCHE NELLA VERSIONE LETTO GRAZIE ALLE DIMENSIONI DEL MATERASSO NELLA MISURA PIÙ GRANDE 180x200.

ROGER IS A SOFA BED WITH A COMPLETELY REMOVABLE COVER, ITS TIMELESS DESIGN THERE TO BE LIVED. THE BED VERSION IS EXTREMELY COMFORTABLE TOO, THANKS TO THE MATTRESS IN THE BIGGEST SIZE 180x200.

ELLIOT

CHAISE LONGUE

Design Marconato&Zappa
Cm. 110x188x76 h.



ELLIOT SI ADATTA A QUALSIASI TIPO DI ARREDAMENTO: PERFETTO NEL CONTESTO CLASSICO, RISALTA IN MANIERA ORIGINALE NELL'AMBIENTE MODERNO COME UNA PREZIOSA OPERA D'ARTE. CARATTERIZZATO DALLA LAVORAZIONE CAPITONNÉ SUI BRACCIOLI E SULLO SCHIENALE È UN DIVANO ATTUALE, RAFFINATO E RICERCATO.

ELLIOT ADAPTS TO ANY DECOR SCHEME: PERFECT IN CLASSICAL SURROUNDINGS, IT ALSO STANDS OUT WITH ORIGINAL STYLE IN A MODERN SETTING, LIKE AN EXQUISITE ARTWORK. FEATURING A QUILTED EFFECT ON BACK AND ARMRESTS, THIS SOFA IS CURRENT, REFINED AND DESIRABLE.

ELLIOT

SOFA

Design Marconato&Zappa
Cm. 260x100x76 h.

“SENZA L'ELEGANZA
DEL CUORE NON C'È
ELEGANZA.”

“WITHOUT ELEGANCE OF THE HEART,
THERE IS NO ELEGANCE”.

(Yves Saint Laurent)



DIVANO ELLIOT, CHAISE LONGUE ELLIOT, TAVOLINO CHARME.
ELLIOT SOFA, ELLIOT CHAISE LONGUE, CHARME COFFEE TABLE.

GRACE

ARMCHAIR

Cm. 80x78x103 h.

LEGGERE INCLINAZIONI E DOLCI CURVE CONTRADDISTINGUONO GRACE, DONANDOLE UN ASPETTO CLASSICO E CONTEMPORANEO ALLO STESSO TEMPO.

GRACE IS DISTINGUISHED BY SLIGHT INCLINATIONS AND GENTLE CURVES, FOR AN APPEARANCE THAT'S BOTH CONTEMPORARY AND CLASSICAL.



VANITY

ARMCHAIR

Cm. 80x77x82 h.



LINEE MORBIDE, SINUOSE, ED UN AMPIO SCHIENALE AVVOLGENTE CON COMODI BRACCIOLI; VANITY È UNA POLTRONCINA CHE SINTETIZZA I CONCETTI DI ELEGANZA DESIGN.

SOFT, SINUOUS LINES AND AN INVITING BACKREST WITH COMFORTABLE ARMS; THE VANITY EASY CHAIR ENCAPSULATES THE CONCEPTS OF ELEGANCE AND DESIGN.

JACK ARMCHAIR

Design Marconato&Zappa
Cm. 78x87x82 h.



LA POLTRONA JACK SINTETIZZA I CONCETTI DI SEMPLICITÀ ED ELEGANZA;
È CARATTERIZZATA DALLE LINEE CURVE E SINUOSE CHE NE EVIDENZIANO IL DESIGN.

THE JACK EASY CHAIR COMBINES SIMPLICITY AND ELEGANCE, WITH SINUOUSLY CURVING
LINES THAT SHOWCASE THE DESIGN.



MARGOT

ARMCHAIR

Design Marconato&Zappa
Cm. 78x77x83 h.

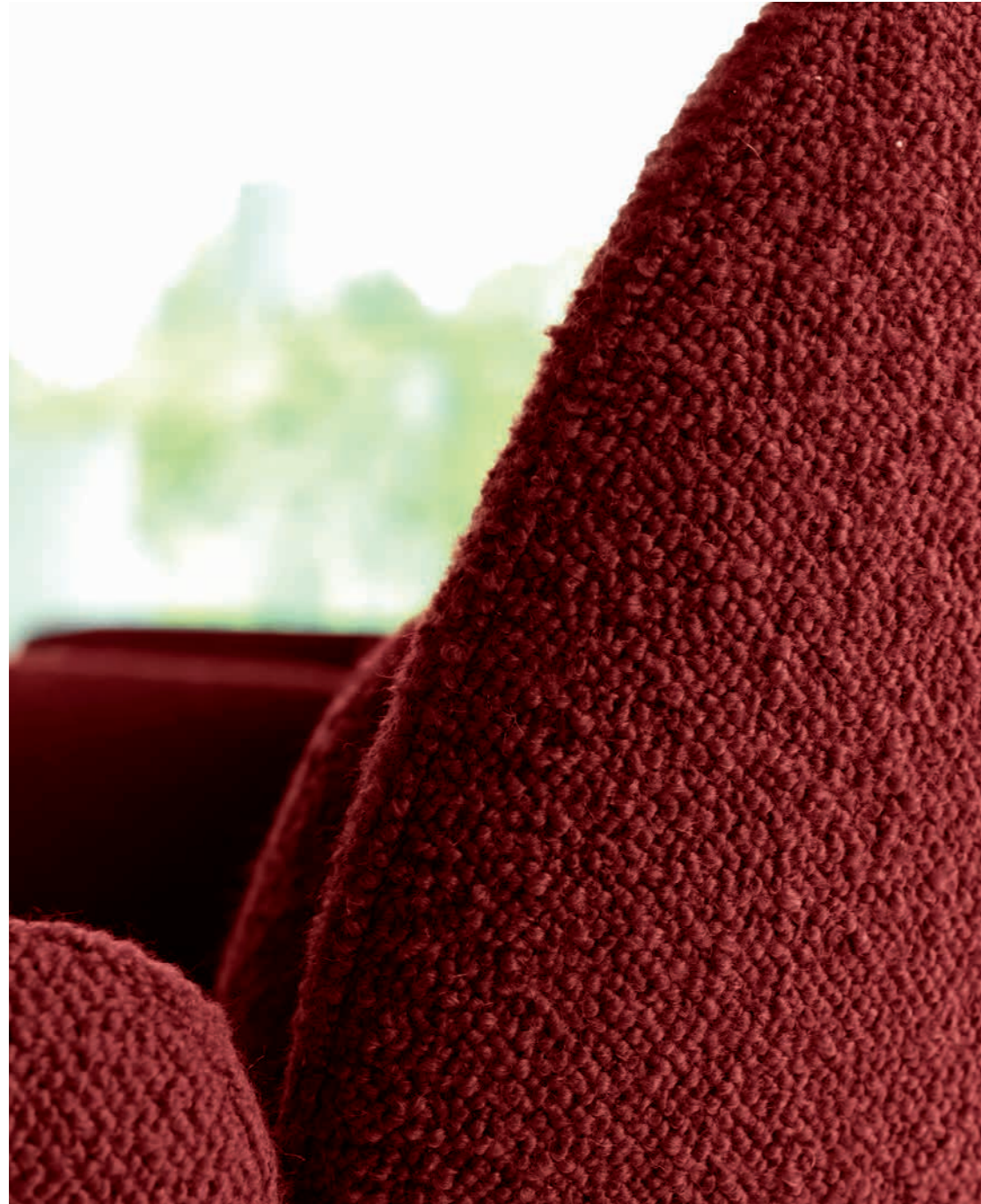

MARGOT, UNA POLTRONCINA COMPATTA E VERSATILE DAL GUSTO ATTUALE, UN SEGNO PULITO, RIGOROSO, ESSENZIALE. PROGETTATA PER USI DIFFERENTI, DA SEDUTA DA LIVING O PER GLI SPAZI COMUNI.

MARGOT IS A COMPACT, VERSATILE EASY CHAIR WITH CONTEMPORARY TASTE AND A RIGOROUS, CLEAN, MINIMALIST STYLE. IT'S DESIGNED FOR A RANGE OF USES FROM.



PLAZA

ARMCHAIR

Design Marconato&Zappa
Cm. 78x78x72 h.

POLTRONA DAL DESIGN CONTEMPORANEO CON UNA FORMA CURVA DELLA STRUTTURA CHE PUÒ ESSERE RIVESTITA IN CUIOETTO, PELLE E TESSUTO.

CONTEMPORARY DESIGN SOFA WITH A CURVED FRAME THAT CAN BE COVERED WITH CUIOETTO LEATHER, LEATHER AND FABRIC.



GUEST

ARMCHAIR & POUFF

Design Marconato&Zappa
Cm. 73x70x72 h.
Cm. 58x47x43 h. (pouf)

ALCUNE PERSONE
PENSANO CHE IL LUSO
SIA L'OPPOSTO DELLA POVERTÀ.
NON LO È.
È L'OPPOSTO DELLA VOLGARITÀ.

SOME PEOPLE THINK THAT LUXURY
IS THE OPPOSITE OF POVERTY.
IT IS NOT. IT IS THE OPPOSITE OF VULGARITY.

(Coco Chanel)



ALLURE

COFFEE TABLE

Design Marconato&Zappa
Cm. 140x70x39 h.
Cm. 70x70x39 h.
Cm. 50x50x54 h.



ELEGANTI E GRAZIOSI, I TAVOLINI ALLURE VIVONO UN DESIGN SENZA TEMPO, ESPRESSIONE DELLO STILE MINIMALISTA. UN'ELEGANZA BASATA SUL CONTRASTO TRA LA STRUTTURA IN METALLO SOTTILE E GEOMETRICA E LA MATERICITÀ DEI PIANI IN VERO MARMO DALLE VENATURE MAI UGUALI.

THE GRACEFUL AND ELEGANT ALLURE COFFEE TABLES ARE A TIMELESS DESIGN WITH MINIMALIST STYLE. THEIR ELEGANCE STEMS FROM THE CONTRAST BETWEEN THE SLEEK GEOMETRIC METAL STRUCTURE AND THE IRREGULAR VEINING OF THE REAL MARBLE TOPS, ALWAYS DIFFERENT.



FOR YOU

COFFEE TABLE

Design Marconato&Zappa
Cm. ø42,5x47 h.

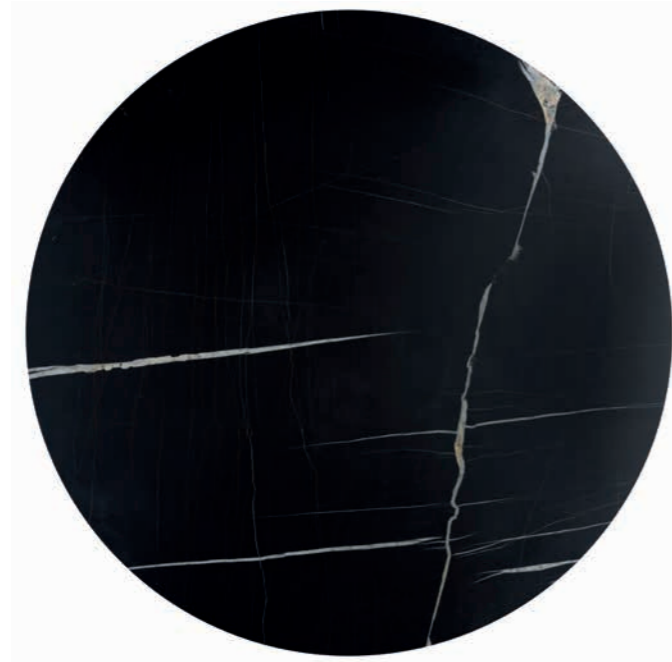

FOR YOU È UNA PROPOSTA DI TAVOLINI ANTICONFORMISTA DAL DESIGN LIBERO DA OGNI VINCOLO; LA STRUTTURA IN METALLO PUÒ AVERE IL PIANO IN MARMO OPPURE RIVESTITO IN CUIOETTO CON CUCITURE A VISTA ESEGUITE A MANO.

FOR YOU IS FAMILY OF UNCONVENTIONAL COFFEE TABLES THAT ARE FREE FROM ALL LIMITS: THE METAL STRUCTURE CAN BE TOPPED WITH MARBLE OR COVERED IN CUIOETTO LEATHER WITH EXPOSED HAND STITCHING.



BRERA

POUFF

Design Marconato&Zappa

Cm. 100x100x34 h.

Cm. 50x50x34 h.



IL POUFF BRERA COMPLETA IL LIVING, UN PICCOLO UNIVERSO DELLA QUOTIDIANITÀ CHE RACCONTA I GUSTI E LE EMOZIONI DI CHI VIVE LA CASA.

THE BRERA POUF COMPLETES YOUR LIVING ROOM, THAT SMALL EVERYDAY UNIVERSE THAT REFLECTS THE TASTES AND EMOTIONS OF THE HOUSE'S INHABITANTS.



TAPE

COFFEE TABLE

Design Marconato&Zappa
Cm. ø100x40 h.
Cm. ø100x32 h.
Cm. ø62x55 h.



ARIEL

ARMCHAIR

Cm. 58x63x87 h.



PICCOLA E GRAZIOSA PER UN DESIGN SENZA TEMPO:
ARIEL È L'ESPRESSIONE DELLO STILE MINIMALISTA

SMALL AND GRACEFUL FOR TIMELESS DESIGN:
ARIEL IS THE EMBODIMENT OF MINIMALIST STYLE.



INFORMAZIONI TECNICHE

TECHNICAL INFORMATION

CTS
ITALIAN SOFAS



IKON

Design Marconato&Zappa

Struttura: realizzata in legno di Abete e pannelli di legno multistrati. Il molleggio è ottenuto con cinghie elastiche intrecciate larghezza 90, rivestita in poliuretano a densità differenziata PF 30 e T 40 e tela di cotone 150 gr con vellutino.

Imbottitura: cuscini seduta in piuma d'oca sterilizzata con inserto in poliuretano a densità differenziata T 30 e T 40 e rivestiti in pelle ovo di cotone, cuscini schienali in piumafill.

Imbottitura dei cuscini in versione poliuretano: cuscini seduta in poliuretano espanso a densità differenziata T 30 e T 40 rivestiti con fibra di Dacron accoppiata con tela di cotone., cuscini schienali in Piumafill.

Rivestimento: tessuto completamente sfoderabile.

Finiture: base in metallo cromato o verniciata Brun Sable, Nero opaco o Oro con appoggio a terra su puntali con materiale termoplastico.

Frame: made in Fir wood and multi-ply panels. The support system is created using 90 cm wide interwoven elastic straps, covered in polyurethane with differentiated densities PF 30 and T 40 and 150 g cotton cloth with velveteen.

Padding: seat cushions in sterilized goose down with polyurethane insert with differentiated densities T 30 and T 40 and covered in cotton muslin, back cushions in Piumafill.

Padding of the cushions in polyurethane version: seat cushions in polyurethane foam with differentiated density T 30 and T 40 covered with Dacron fibre coupled with cotton cloth, back cushions in Piumafill.

Cover: completely removable fabric.

Finishes: base in chrome-plated metal or painted in Brun Sable, matt Black or Gold with ground support on tips with thermoplastic material.

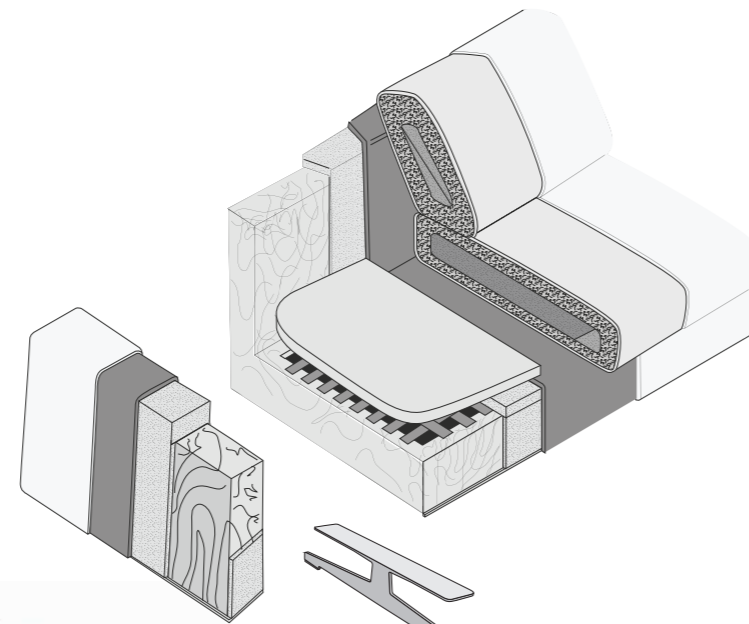

VARIANTI PIEDINI IN METALLO ALUMINIUM FEET OPTIONS



Verniciato Nero
Black painting

Verniciato Brun Sable
Brun Sable painting

Verniciato Oro
Gold painting

Cromo
Chrome

VARIANTI COLORI PROFILO COLOUR OPTIONS PIPING

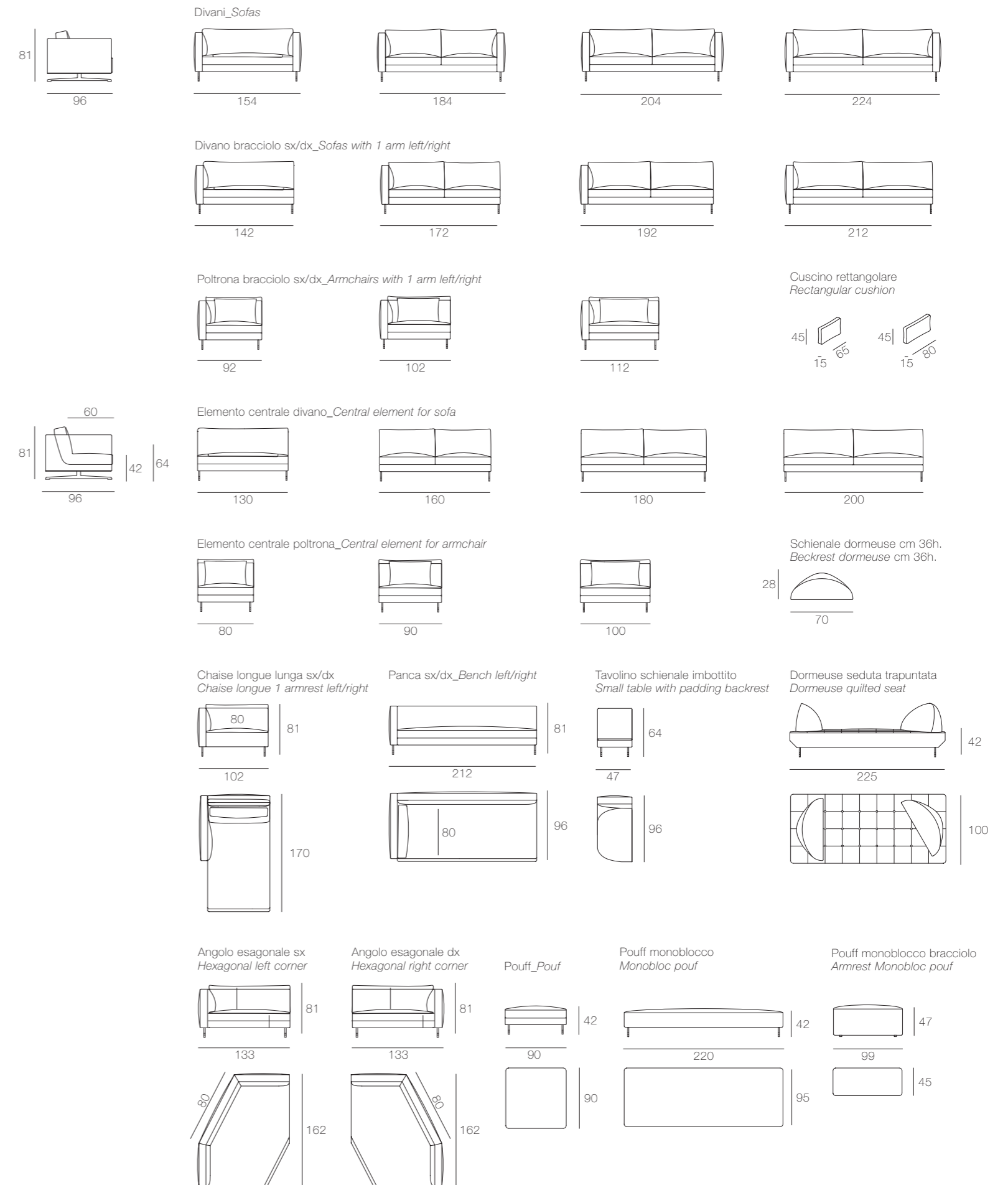

IKON

Design Marconato&Zappa

Composizione pagina 12-15

Divano Ikon: rivestimento art. 1870/1, cat. Extra; cuscino decorativo art.1830/2 cat. Extralux. Rivestimento bracciolo art. 1830/2, cat. Extralux.

Piedini verniciati Brun Sablè con mensola marmo Sahara Noir.

Poltrona Margot: rivestimento art. 1690/7, cat. H.

Basamento Frassino tinto Wengè.

Pouff Brera 50x50: rivestimento art. 1720/104, cat. Extra. Piedini in abs Nero.

Tavolino For you: basamento verniciato Brun Sablè con piano Cuoietto Coloniale.

Tavolino Allure 50x50 / 70x70: basamento verniciato Brun Sablè con piano marmo Calacatta. Tavolino Allure 70x140: basamento verniciato Brun Sablè con piano marmo Sahara Noir.

Layout page 12-15

Ikon sofa: cover art. 1870/1, cat. Extra; decorative cushion art.1830/2 cat. Extralux. Armrest cover art. 1830/2, cat. Extralux.

Brun Sablè painted feet with Sahara Noir marble shelf.

Margot armchair: cover art. 1690/7, cat. H. Wengè stained Ash base.

Brera Pouf 50x50: cover art. 1720/104, cat. Extra. Feet in Black abs.

For you coffee table: Brun Sablè painted base with Colonial cuoietto leather top.

Allure coffee table 50x50 / 70x70: Brun Sablè painted base with Calacatta marble top. Allure coffee table 70x140: Brun Sablè painted base with Sahara Noir marble top.

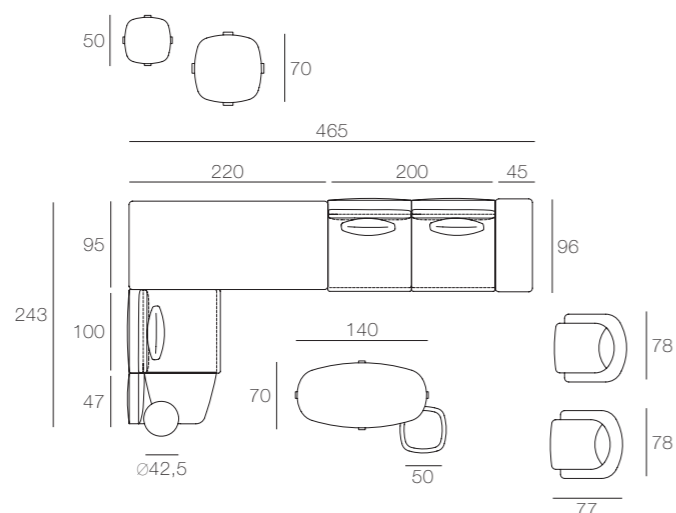

Composizione pagina 17

Divano Ikon: rivestimento fascia davanti, cuscino seduta e cuscino schienale art. 1850/8, cat. VIP. Struttura e pouf bracciolo art. 1830/16 cat. Extralux; cuscino decorativo art. 1720/301, cat. Extra. Piedini verniciati Nero, mensola cuoietto Tortora.

Pouff Brera 50x50: rivestimento art. 1830/16, cat. Extralux. Piedini in abs Nero.

Tavolino For you: basamento verniciato Nero con piano marmo Calacatta.

Tavolino Allure 70x70: basamento verniciato Brun Sablè con piano marmo Calacatta.

Layout page 17

Ikon sofa: front band cover, seat cushion and back cushion art. 1850/8, cat. VIP. Frame and armrest pouf art. 1830/16 cat. Extralux; decorative cushion art. 1720/301, cat. Extra. Black painted feet, Dove grey cuoietto leather shelf.

Brera Pouf 50x50: cover art. 1830/16, cat. Extralux. Feet in Black abs.

For you coffee table: Black painted base with Calacatta marble top.

Allure coffee table 70x70: Brun Sablè painted base with Calacatta marble top.

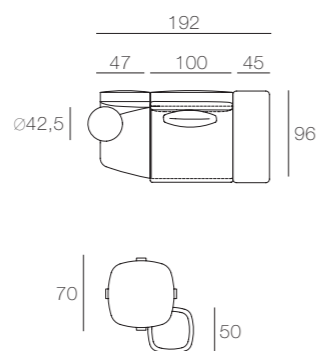

Composizione pagina 18-19

Divano Ikon: rivestimento art. 1870/1, cat. Extra; cuscino decorativo art.1830/2 cat. Extralux. Rivestimento bracciolo art. 1830/2, cat. Extralux.

Piedini verniciati Brun Sablè con mensola marmo Sahara Noir.

Poltrona Margot: rivestimento art.1720/138, cat. Extra.

Basamento Frassino tinto Wengè.

Pouff Brera 50x50: rivestimento art. 1720/104, cat. Extra. Piedini in abs Nero.

Tavolino For you: basamento verniciato Brun Sablè con piano Cuoietto Coloniale.

Tavolino Allure 50x50: basamento verniciato Brun Sablè con piano marmo Calacatta. Tavolino Allure 140x70: basamento verniciato Brun Sablè con piano marmo Sahara Noir.

Layout page 18-19

Ikon sofa: cover art. 1870/1, cat. Extra; decorative cushion art.1830/2 cat. Extralux. Armrest cover art. 1830/2, cat. Extralux.

Brun Sablè painted feet with Sahara Noir marble shelf.

Margot armchair: cover art.1720/138, cat. Extra.Wengè stained Ash base.

Brera pouf 50x50: cover art. 1720/104, cat. Extra. Feet in Black abs.

For you coffee table: Brun Sablè painted base with Colonial cuoietto leather top.

Allure coffee table 50x50: Brun Sablè painted base with Calacatta marble top. Allure coffee table 140x70: Brun Sablè painted base with Sahara Noir marble top.

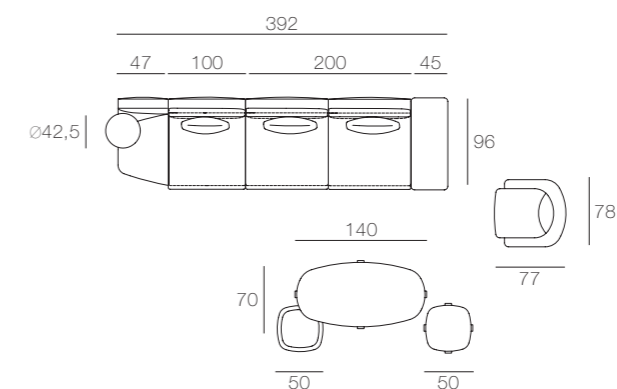

Composizione pagina 22-23

Divano Ikon Monoblocco: rivestimento art. 1850/1, cat. VIP; cuscino decorativo art. 1830/1 cat. Extralux. Piedi verniciati Nero, mensola marmo Calacatta.

Poltrona Plaza: rivestimento esterno cuoietto e rivestimento interno e seduta art. 1810/04, cat. H; cuscino art. 1750/38, cat. H. Piedi verniciati Nero.

Pouff Brera 50x50: rivestimento art. 1830/1, cat. Extralux. Piedini in abs Nero.

Tavolino For you: basamento verniciato Brun Sablè con piano marmo Calacatta.

Tavolino Allure 140x70: basamento verniciato Brun Sablè con piano marmo Calacatta.

Layout page 22-23

Ikon Monobloc sofa: cover art. 1850/1, cat. VIP; decorative cushion art. 1830/1 cat. Extralux. Black painted feet, Calacatta marble shelf.

Plaza armchair: cuoietto leather outer cover and inner cover and seat art. 1810/04, cat. H; cushion art. 1750/38, cat. H. Black painted feet.

Brera Pouf 50x50: cover art. 1830/1, cat. Extralux. Feet in Black abs.

For you coffee table: Brun Sablè painted base with Calacatta marble top.

Allure coffee table 140x70: Brun Sablè painted base with Calacatta marble top.

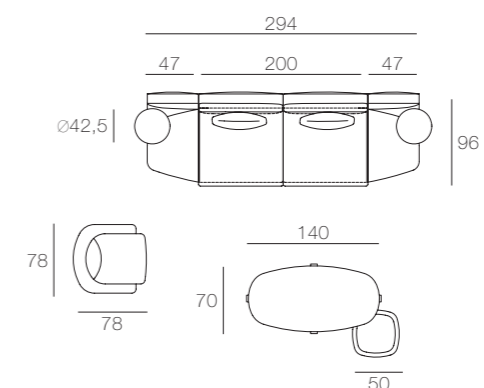

MONOBLOCCO
Monobloc

IKON

Design Marconato&Zappa

Composizione pagina 27-29

Divano Ikon: rivestimento art. 1840/10, cat. H; cuscino decorativo art. 1820/70/1, cat. Extra. Piedini verniciati Nero.

Poltrona Guest: rivestimento art. 4264/19, cat. Pelle accoppiata. Piedini verniciati Nero.

Pouff Brera 50x50: rivestimento art. 1830/1, cat. Extralux. Piedini in abs Nero.

Tavolino For you: basamento verniciato Nero con piano marmo Calacatta.

Tavolino Allure 70x70 /140x70: basamento verniciato Nero con piano marmo Calacatta.

Layout page 27-29

Ikon sofa: cover art. 1840/10, cat. H; decorative cushion art. 1820/70/1, cat. Extra. Black painted feet.

Guest armchair: cover art. 4264/19, cat. coupled leather. Black painted feet.

Brera Pouf 50x50: cover art. 1830/1, cat. Extralux. Feet in Black abs.

For you coffee table: Black painted base with Calacatta marble top.

Allure coffee table 70x70 /140x70: Black painted base with Calacatta marble top.

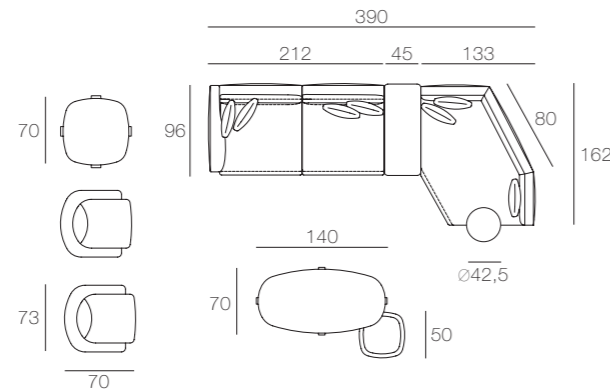

Composizione pagina 31-33

Divano Ikon Monoblocco: rivestimento pelle California 675 gabbiano cat. Anilina; cuscino decorativo art. 1860/501, cat. Extra. Piedini verniciati Nero.

Dormeuse Ikon: rivestimento art. 4263/18, cat. Extra; cuscino decorativo art. 1860/500, cat. Extra. Piedini verniciati Nero.

Poltrona Jack: rivestimento art. 1850/13, cat. VIP. Struttura Frassino tinto Nero.

Pouff Brera 50x50: rivestimento art. 1720/104, cat. Extra. Piedini in abs Nero.

Tavolino Allure 50x50 /70x70: basamento verniciato Nero con piano marmo Calacatta. Tavolino Allure 140x70: basamento verniciato Nero con piano marmo Sahara Noir.

Layout page 31-33

Ikon Monobloc sofa: California 675 seagull leather cover cat. Anilina; decorative cushion art. 1860/501, cat. Extra. Black painted feet.

Ikon Daybed: cover art. 4263/18, cat. Extra; Decorative Cushion art. 1860/500, cat. Extra. Black painted feet.

Jack armchair: cover art. 1850/13, cat. VIP Black stained Ash frame.

Brera Pouf 50x50: cover art. 1720/104, cat. Extra. Feet in Black abs.

Allure coffee table 50x50 /70x70: Black painted base with Calacatta marble top.

Allure 140x70 coffee table: Black painted base with Sahara Noir marble top.

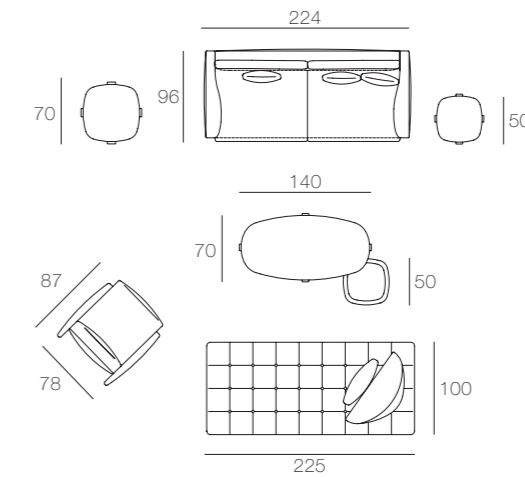

MONOBLOCCO
Monobloc

Composizione pagina 38-41

Divano Ikon: rivestimento art. 1870/11, cat. Extra; cuscino decorativo art. 1850/6, cat. VIP. Piedini verniciati Nero.

Poltrona Grace: rivestimento art. 1850/6, cat. Vip. Base girevole Nero.

Poltrona Ariel: rivestimento art. 1880/12, cat. Extra. Base girevole Nero.

Pouff Capetown: rivestimento art. 1860/400, cat. Extra. Piedini in abs Nero.

Tavolino For you: basamento verniciato Nero con piano marmo Calacatta.

Tavolino Tape Ø100x32h: basamento Frassino tinto Nero con piano marmo Sahara Noir.

Layout page 38-41

Ikon sofa: cover art. 1870/11, cat. Extra; decorative cushion art. 1850/6, cat. VIP. Black painted feet.

Grace armchair: cover art. 1850/6, cat. VIP. Black swivel base.

Ariel armchair: cover art. 1880/12, cat. Extra. Black swivel base.

Capetown pouf: cover art. 1860/400, cat. Extra. Feet in Black abs.

For you coffee table: Black painted base with Calacatta marble top.

Tape coffee table Ø100x32h: Black stained Ash base with Sahara Noir marble top.

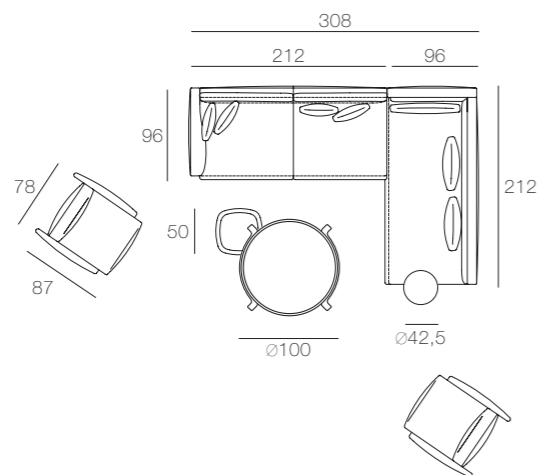

IKON MONOBLOCCO

Design Marconato&Zappa

Struttura: realizzata in legno di Abete e pannelli di legno multistrati. Il molleggio è ottenuto con cinghie elastiche intrecciate larghezza 90, rivestita in poliuretano a densità differenziata PF 30 e T 40 e tela di cotone 150 gr con vellutino.

Imbottitura: cuscini seduta in poliuretano espanso a densità differenziata T 30 e T 40 rivestiti con fibra di Dacron accoppiata con tela di cotone, cuscini schienali in Piumafill.

Rivestimento: in pelle o in tessuto completamente sfoderabile.

Finiture: base in metallo cromato o verniciata Brun Sable, Nero opaco o Oro con appoggio a terra su puntali con materiale termoplastico.

Frame: made in Fir wood and multi-ply panels. Suspension support with 90 cm wide interwoven elastic straps, covered in polyurethane with differentiated densities PF 30 and T 40 and 150 g cotton cloth with velveteen.

Padding: seat cushions in polyurethane foam with differentiated density T 30 and T 40 covered with Dacron fibre coupled with cotton cloth, back cushions in Piumafill.

Cover: in leather or completely removable fabric.

Finishes: base in chromed metal or painted Brun Sable, matt Black or Gold with ground support on tips with thermoplastic material.

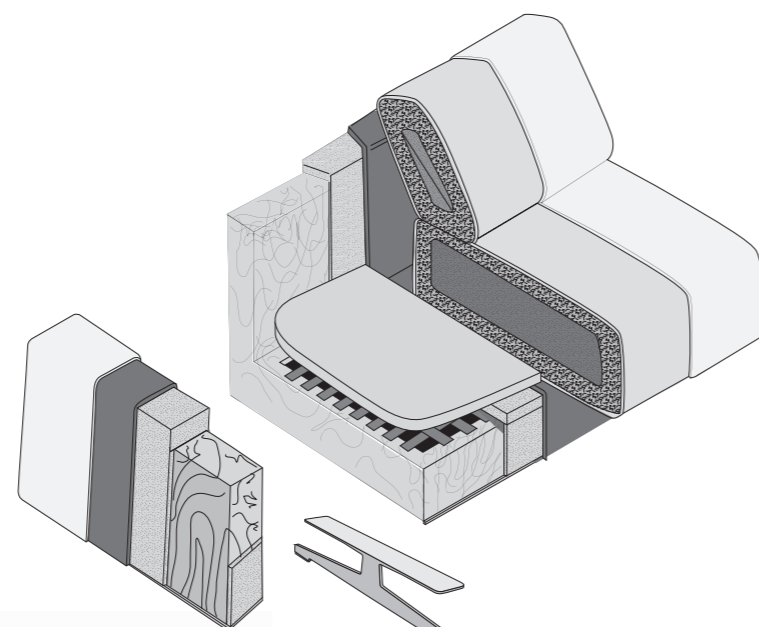

VARIANTI PIEDINI IN METALLO ALUMINIUM FEET OPTIONS



Verniciato Nero
Black painting

Verniciato Brun Sable
Brun Sable painting

Verniciato Oro
Gold painting

Cromo
Chrome

VARIANTI COLORI PROFILO COLOUR OPTIONS PIPING



40 Bianco
40 White

36 Burro
36 Butter

37 Panna
37 Cream

136 Sabbia
136 Sand

168 Castoro
168 Beaver

142 Nocciola
142 Hazelnut

68 Ambra
68 Amber

85 Rubino
85 Ruby

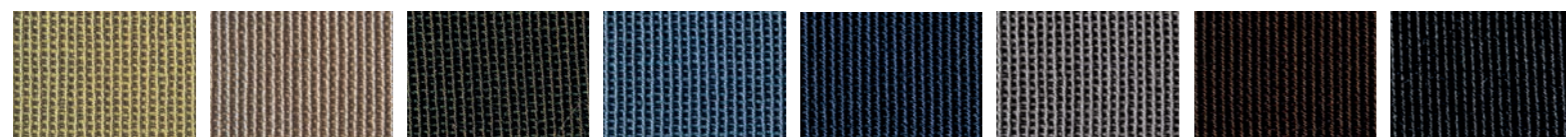

123 Pistacchio
123 Pistachio

164 Tortora
164 Dove-grey

175 Muschio
175 Moss

173 Avio
173 Air-force blue

116 Oceano
116 Ocean

46 Ferro
46 Iron

99 Moro
99 Dark brown

41 Nero
41 Black

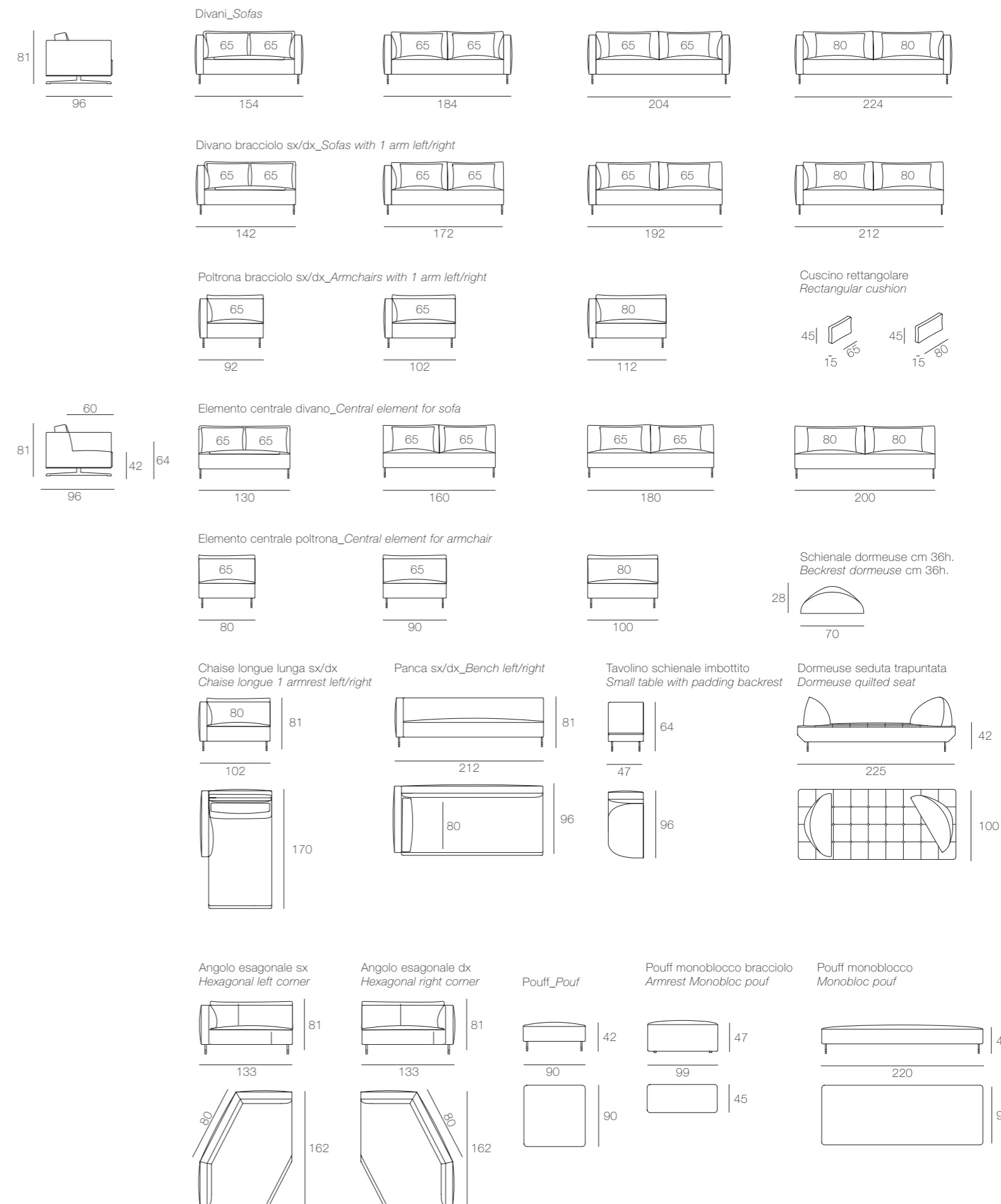

CREO

Design Marconato&Zappa

Struttura: in multistrato di Pioppo mm 30. Molleggio ottenuto con cinghie elastiche Intes Elsbelt 790/S larghezza mm 90.

Imbottitura della struttura: poliuretano espanso a densità differenziata T75 e T25. Resinato accoppiato con vellutino gr 200.

Imbottitura dei cuscini versione piuma: cuscino schienale in piuma d'oca SMOB 10 con inserto in poliuretani espanso a densità differenziata T30 e T21 piumex rivestito con fodera pelleovo di cotone. Cuscino sedile in piuma d'oca SMOB 10 con inserto in poliuretano espanso a densità differenziata T30 e T40 rivestito con fodera pelleovo di cotone. Cuscino bracciolo in poliuretano espanso T40 rivestito con termolegato accoppiato con tela 200 gr.

Imbottitura dei cuscini versione poliuretano: cuscino schienale in poliuretano espanso a densità differon 400 gr accoppiato con tela di cotone. Cuscino sedile in poliuretano espanso a densità differenziata T35 Eucalypto on 400 gr accoppiato con tela di cotone. Cuscino bracciolo in poliuretano espanso T40 rivestito con termolegato accoppiato con tela 200 gr.

Rivestimento: rivestimento in pelle o in tessuto completamente sfoderabile.

Finiture: base in metallo cromato o verniciata Brun Sable, Nero opaco o Oro con appoggio a terra su puntali con materiale termoplastico.

Frame: in Poplar multi-ply 30 mm. Suspension support with elastic straps Intes Elsbelt 790/S width mm 90.

Frame padding: T75 and T25 differentiated density polyurethane foam. Resin coupled with velveteen 200 g.

Cushion filler (down version): SMOB 10 goose down back cushion with differentiated density polyurethane foam insert T30 and T21 piumex covered with cotton muslin lining. SMOB 10 goose down seat cushion with differentiated density polyurethane foam insert T30 and T40 covered with cotton muslin lining. Armrest cushion in polyurethane foam T40 coated with thermo-bonded fibre coupled with cotton cloth 200 gr.

Padding of the polyurethane version cushions: back cushion in polyurethane foam with different density 400 gr coupled with cotton cloth. Seat cushion in polyurethane foam with differentiated density T35 Eucalypto on 400 gr coupled with cotton cloth. Armrest cushion in polyurethane foam T40 coated with thermo-linked coupled with cotton cloth 200 gr.

Cover: leather or fabric cover completely removable.

Finishes: base in chromed metal or painted Brun Sable, matt Black or Gold with ground support on tips with thermoplastic material.

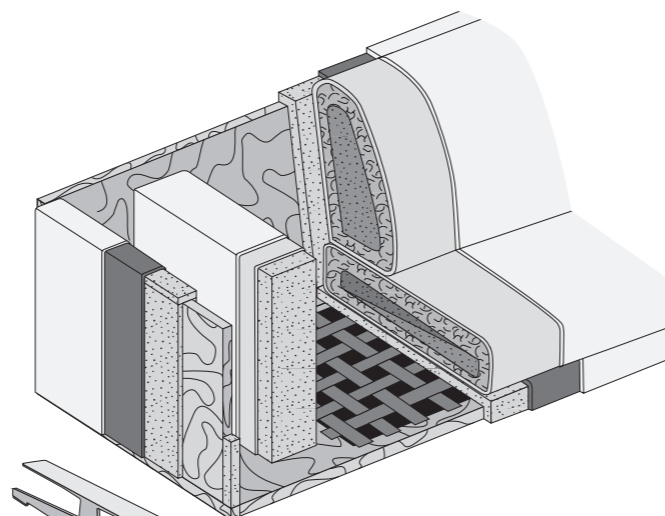

VARIANTI PIEDINI IN METALLO ALUMINIUM FEET OPTIONS



- Verniciato Nero
Black painting
- Verniciato Brun Sablè
Brun Sablè painting
- Verniciato Oro
Gold painting
- Cromo
Chrome

Composizione pagina 42-43 / Layout page 42-43

Divano Time: rivestimento art. 1720/104, cat. Extra. Cuscino decorativo art. 1720/104, cat. Extra. Piedini verniciati Nero.

Poltrona Margot: rivestimento in pelle Nabuk colore 35, cat. Nabuk. Piedini in metallo verniciato Nero.

Pouff Brera 50x50: rivestimento art. 1720/104, cat. Extra. Piedini in abs Nero.

Tavolino Allure 140x70: basamento verniciato Nero con piano marmo Sahara Noir.

Time Sofa: Cover art. 1720/104, cat. Extra. Decorative cushion art. 1720/104, cat. Extra. Black painted feet.

Margot armchair: Nubuck leather cover colour 35, cat. Nubuck. Feet in Black painted metal.

Brera Pouf 50x50: cover art. 1720/104, cat. Extra. Feet in Black abs.

Allure coffee table 140x70: Black painted base with Sahara Noir marble top.

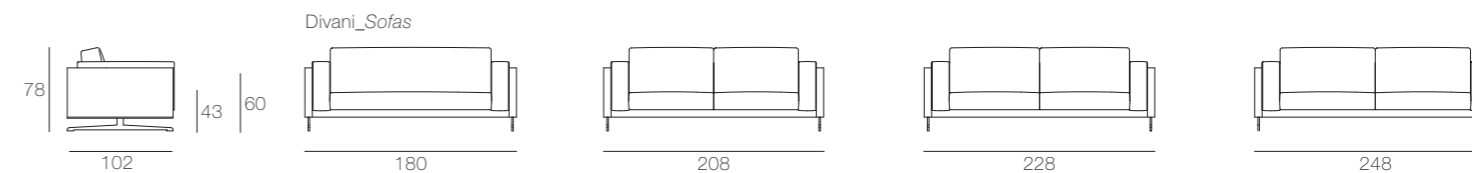
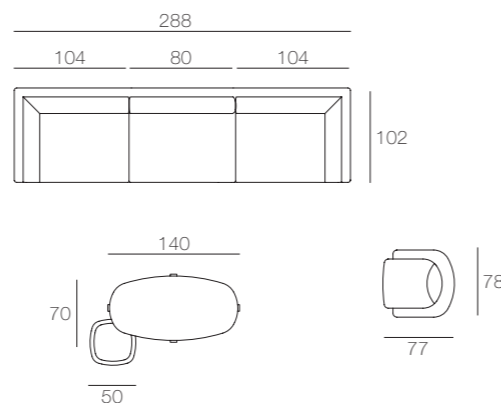

Divani_Sofas

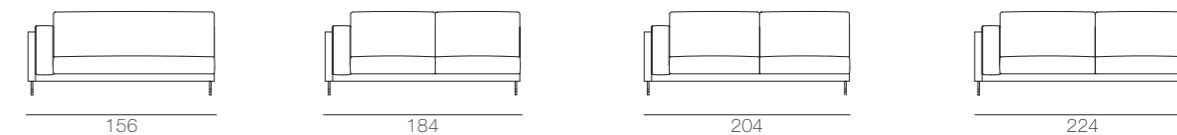

Poltrona_Armchair



Poltroncina_Small armchair

Poltrona bracciolo sx/dx_Armchairs with 1 arm left/right



Divano centrale_Central Sofa

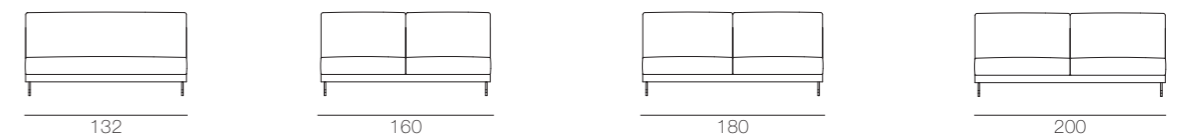

Poltrona centrale_Central armchair



Angolo retto_Straight corner

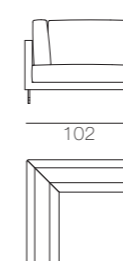

Chaise longue bracciolo sx/dx
Chaise longue with 1 arm left/right

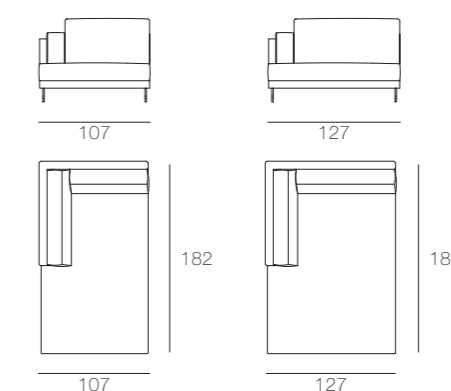

Pouff_Pouf

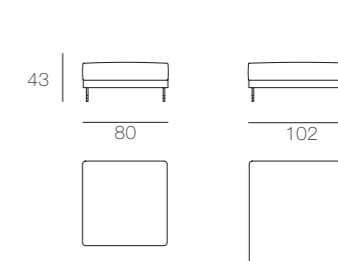

TIME

Design Marconato&Zappa

Struttura: in multistrato di Pioppo mm 30. Molleggio ottenuto con cinghie elastiche Intes Elsbelt 790/S larghezza mm 90.

Imbottitura della struttura: poliuretano espanso a densità differenziata T75 e T25. Resinato accoppiato con vellutino gr 200.

Imbottitura dei cuscini versione piuma: cuscino schienale in piuma d'oca SMOB 10 con inserto in poliuretani espanso a densità differenziata T30 e T21 piumex rivestito con fodera pelleovo di cotone. Cuscino sedile in piuma d'oca SMOB 10 con inserto in poliuretano espanso a densità differenziata T30 e T40 rivestito con fodera pelleovo di cotone. Cuscino bracciolo in poliuretano espanso T40 rivestito con termolegato accoppiato con tela 200 gr.

Imbottitura dei cuscini versione poliuretano: cuscino schienale in poliuretano espanso a densità differon 400 gr accoppiato con tela di cotone. Cuscino sedile in poliuretano espanso a densità differenziata T35 Eucalipto on 400 gr accoppiato con tela di cotone. Cuscino bracciolo in poliuretano espanso T40 rivestito con termolegato accoppiato con tela 200 gr.

Rivestimento: rivestimento in pelle o in tessuto completamente sfoderabile.

Finiture: basamento in Frassino tinto naturale, Noce, Noce scuro, Wengè, Bianco poro aperto e Nero poro aperto.

Frame: in Poplar multi-ply 30 mm. Suspension support with elastic straps Intes Elsbelt 790/S width mm 90.

Frame padding: T75 and T25 differentiated density polyurethane foam. Resin coupled with velveteen 200 g.

Cushion filler (down version): SMOB 10 goose down back cushion with differentiated density polyurethane foam insert T30 and T21 piumex covered with cotton muslin lining. SMOB 10 goose down seat cushion with differentiated density polyurethane foam insert T30 and T40 covered with cotton muslin lining. Armrest cushion in polyurethane foam T40 coated with thermo-bonded fibre coupled with cotton cloth 200 gr.

Padding of the polyurethane version cushions: back cushion in polyurethane foam with differentiated density 400 gr coupled with cotton cloth. Seat cushion in polyurethane foam with differentiated density T35 Eucalyptus on 400 gr coupled with cotton cloth. Armrest cushion in polyurethane foam T40 coated with thermo-bonded fibre coupled with cotton cloth 200 gr.

Cover: leather or fabric cover completely removable.

Finishes: base in Natural stained Ash, Walnut, dark Walnut, Wengè, open-pore White and open-pore Black.

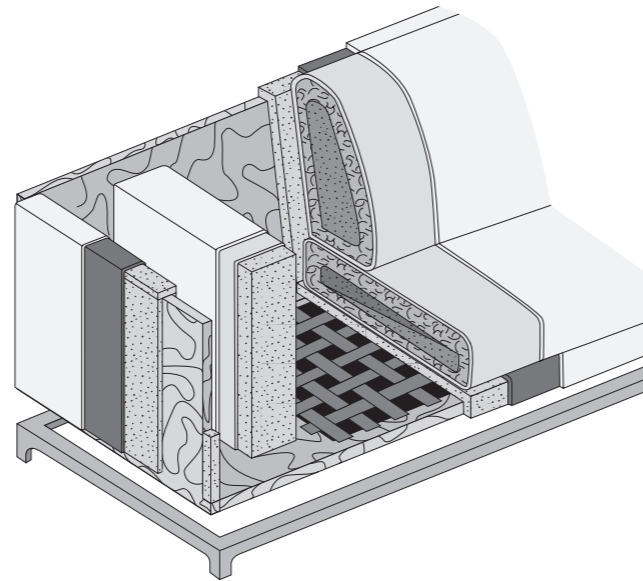

Composizione pagina 45-47 / Layout page 45-47

Divano Time: rivestimento art. 1880/11, cat. G; cuscino decorativo art. 1880/08, cat. Extra. Struttura Frassino tinto Nero.

Poltrona Jack: rivestimento art. 1880/08, cat. EXTRA. Struttura Frassino tinto Nero.

Tavolino Tape Ø100x32h: struttura in Frassino tinto Nero con piano marmo Calacatta. Tavolino Tape Ø100x40h: struttura in Frassino tinto Nero con piano marmo Sahara Noir. Tavolino Tape Ø62x55h: struttura in Frassino tinto Nero con piano marmo Calacatta.

Time Sofa: Cover art. 1880/11, cat. G; decorative cushion art. 1880/08, cat. Extra. Black stained Ash frame.

Jack armchair: cover art. 1880/08, cat. EXTRA. Black stained Ash frame.

Tape coffee table Ø100x32h: Black stained Ash frame with Calacatta marble top. Tape coffee table Ø100x40h: frame in Black stained Ash with Sahara Noir marble top. Tape coffee table Ø62x55h: Black stained Ash frame with Calacatta marble top.

Composizione pagina 48-49 / Layout page 48-49

Divano Time: rivestimento pelle nabuk 15, cat. Pelle nabuk. Basamento Frassino tinto Noce scuro.

Tavolino Charme Ø110x40h: basamento verniciato Oro con piano marmo Emperador.

Time sofa: cover in Nubuck leather 15, cat. Nubuck leather. Base in dark walnut stained Ash.

Charme coffee table Ø110x40h: gold painted base with Emperador marble top.

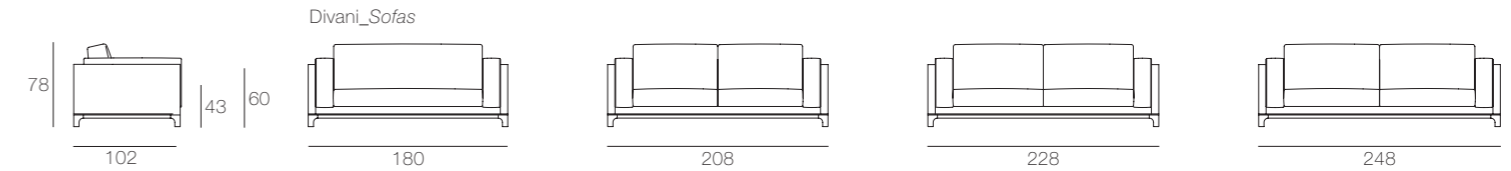

Divano bracciolo sx/dx_Sofas with 1 arm left/right



Poltrona_Armchair

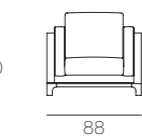
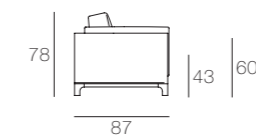
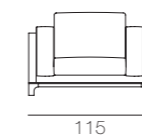
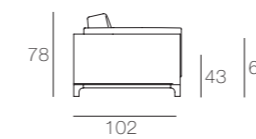

Poltroncina_Small armchair

Poltrona bracciolo sx/dx_Armchair with 1 arm left/right

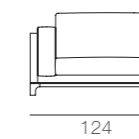
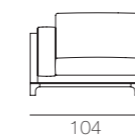

Elemento centrale divano_Central element for sofa

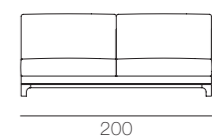
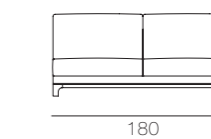
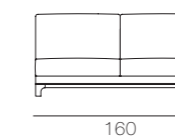
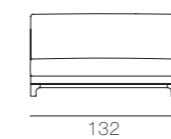

Elemento centrale poltrona_Central element for armchair



Angolo retto_Straight corner

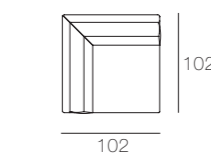

Chaise longue_Chaise longue

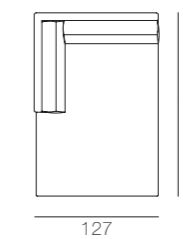
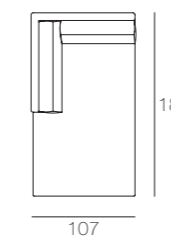

Pouff_Pouf

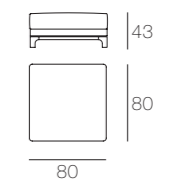
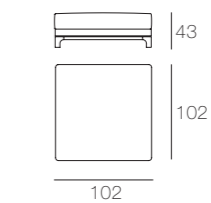

VARIANTI BASAMENTO IN LEGNO WOODEN BASE OPTIONS



Frassino Naturale
Natural Ash

Frassino tinto Noce
Walnut stained Ash

Frassino tinto scuro
Dark stained Ash

Frassino Wengè
Wengè Ash

Frassino laccato
Nero poro aperto
Open-pore Black Ash

Frassino laccato
Bianco poro aperto
Open-pore white Ash

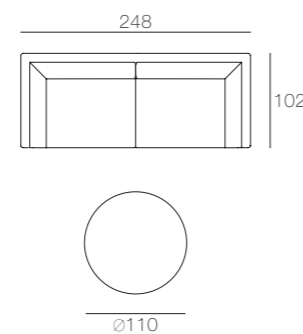
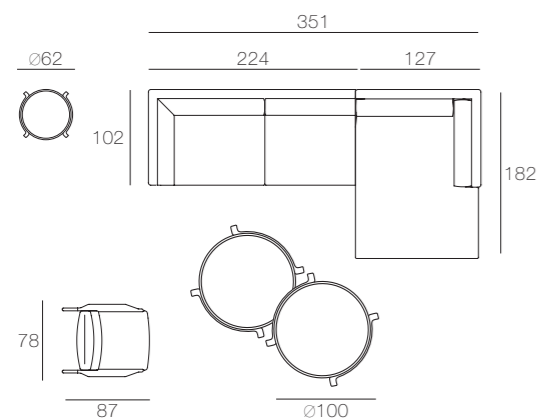

FLAP LARGE

Design Marconato&Zappa

Caratteristiche: il divano si presenta nella versione Flap Large con una maggior profondità di seduta e nella versione Flap con una profondità più equilibrata, e si caratterizza dalla possibilità di sistemare in 10 posizioni la parte alta dello schienale diventando poggia-testa. Morbidi cuscini di seduta possono essere realizzati in piuma d'oca con inserto in poliuretano oppure completamente in poliuretano. Il sistema è completamente sfoderabile.

Struttura: struttura in legno di Abete. Pannelli di legno compensato. Pannello in legno multistrati. Molleggio ottenuto con cinghie elastiche Elasebelt 790/4 mm 90. Meccanismo per movimento parte alta dello schienale funzione poggiatesta.

Imbottitura della struttura: poliuretano espanso a densità differenziate T25 e T75. Resinato 100 gr accoppiato con vellutino.

Imbottitura dei cuscini versione piuma: cuscino sedile in piuma d'oca con inserto in poliuretano espanso a densità differenziata T35 e T30 SM rivestito in pelleoivo di cotone. Cuscino schienale in poliuretano a densità differenziata PF25 SM, OS30 FM T40 F e MTP95 on 400 gr accoppiato con tela di cotone. Poggiareni in piuma d'oca.

Imbottitura dei cuscini versione poliuretano: cuscino sedile in poliuretano espanso a densità differenziate T35 PF e T40 rivestito con Termolegato 400 gr accoppiato con tela di cotone. Cuscino schienale in poliuretano a densità differenziata PF25 SM e on 400 gr accoppiato con tela di cotone. Cuscino poggiareni in piuma d'oca.

Rivestimento: rivestimento in pelle o in tessuto completamente sfoderabile.

Finiture: piedino in alluminio: lucido, satinato o verniciato nei colori Brun Sablé, Nero e Bianco.

Features: the sofa is presented in the Flap Large version with a greater seat depth and in the Flap version with a more balanced depth, and features the possibility of arranging the upper part of the backrest in 10 positions becoming a headrest. Soft seat cushions can be made of goose down with polyurethane insert or entirely in polyurethane. The system is completely removable.

Frame: Fir wood frame. Plywood panels. Multi-ply panel. Suspension support with elastic straps Elasebelt 790/4 mm 90. Mechanism for moving the upper part of the backrest that works as a headrest.

Frame padding: T25 and T75 differentiated density polyurethane foam. Resin 100 gr coupled with velveten.

Cushion filler (down version): goose down seat cushion with differentiated density polyurethane foam insert T35 and T30 SM covered in cotton muslin.

Back cushion in polyurethane: differentiated density PF25 SM, OS30 FM T40 F and MTP95 on 400 gr coupled with cotton cloth. Goose down lower cushion.

Cover: leather or fabric cover, completely removable.

Finishes: aluminium foot: polished, satin-finished or painted in Brun Sablé, Black and white.

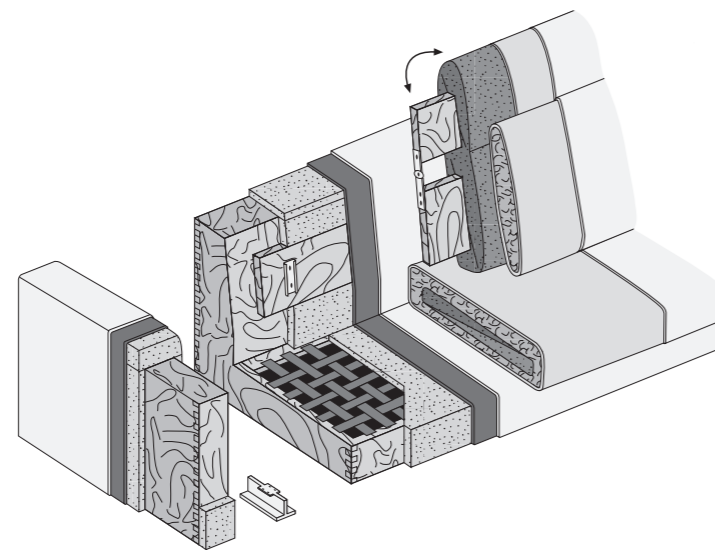

Composizione pagina 52-53 / Layout page 52-53

Divano Flap Large: rivestimento art. 1800/01 cat. H; cuscino decorativo

art. 1830/01 cat. Extralux, piedini Nero.

Poltrona Vanity: rivestimento pelle accoppiata 4264/50 cat. Pelle accoppiata.

Base Frassinio tinto Nero.

Pouf Brera: rivestimento art. 1830/01 cat. Extralux. Piedini in abs Nero.

Tavolino Allure 50x50 / 70x70: basamento verniciato Nero con piano

marmo Calacatta.

Flap Large sofa: cover art. 1800/01 cat. decorative cushion art. 1830/01

cat. Extralux, Black feet.

Vanity armchair: coupled leather cover 4264/50 cat. coupled leather.

Black stained Ash base.

Brera pouf: cover art. 1830/01 cat. Extralux. Feet in Black abs.

Allure coffee table 50x50 / 70x70: Black painted base with Calacatta marble top.

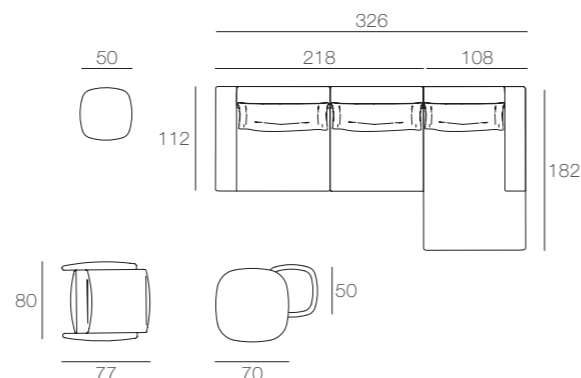

VARIANTI PIEDINI IN METALLO ALUMINIUM FEET OPTIONS



Verniciato Brun Sablé
Brun Sablé painting

Verniciato Nero
Black painting

Alluminio lucido
Aluminium

Alluminio satinato
Satin aluminium

Verniciato Bianco
White painting

ROGER

Design Marconato&Zappa

Caratteristiche: il modello Roger si propone con una vasta gamma di elementi fissi o componibili. Dettagli di alta qualità sono la lavorazione con profilo del rivestimento in tessuto e il cuscinetto reggischiena dietro i cuscini schienale. Speciale rete ortopedica a doghe per la versione con comodo letto. Roger è completamente sfoderabile.

Struttura: in legno di Abete. Pannelli di legno multistrato. Molleggio ottenuto con cinghie elastiche Intes Elasztel 790/4 larghezza 90 mm.

Imbottitura della struttura: poliuretano espanso a densità differenziate T30 N e T75. Resinato accoppiato T1/ sc 200 gr.

Imbottitura dei cuscini versione piuma: cuscino poggiatesta in espanso densità T30. Cuscino schienale in piuma d'oca Oro, con inserto in poliuretano espanso a densità differenziata SH 30 e T21 SS rivestito in pelleovo di cotone. Cuscino sedile in piuma d'oca Oro, con inserto in poliuretano espanso a densità differenziata T35 SP e T30 SM rivestito in pelleovo di cotone.

Imbottitura dei cuscini versione poliuretano: cuscino poggiatesta in espanso densità T30. Cuscino schienale in poliuretano espanso a densità differenziata SH 30 e T21 SS rivestito con fibra di Dacron 400 gr accoppiata con tela di cotone. Cuscino sedile in poliuretano espanso a densità differenziata T35 Eucalipto e T30 SM rivestito con fibra di Dacron 400 gr accoppiata con tela di cotone.

Rivestimento: rivestimento in pelle o in tessuto completamente sfoderabile.

Finiture: piedino in alluminio disponibile nelle finiture: lucido, satinato e verniciato nei colori Brun Sablè, Nero e Bianco.

Features: The Roger model is available with a wide range of fixed or modular elements. High quality details are the processing with fabric cover profile and the lower back cushion behind the back cushions. Special orthopaedic slatted base for the version with comfortable bed. Roger is fully removable.

Frame: in fir wood. Multi-ply wood panels. Suspension support with elastic straps Intes Elasztel 790/4 width 90 mm.

Frame padding: polyurethane foam with differentiated densities T30 N and T75. Coupled resin T1/ sc 200 gr.

Cushion filler (down version): T30 density foam lower back cushion. Back cushion in goose down Gold, with insert in polyurethane foam with differentiated density SH 30 and T21 SS covered in cotton muslin. Seat cushion in goose down Gold, with insert in polyurethane foam with differentiated density T35 SP and T30 SM covered in cotton muslin.

Padding of the polyurethane version cushions: T30 density foam lower back cushion. Back cushion in polyurethane foam with differentiated density SH 30 and T21 SS covered with Dacron fibre 400 gr coupled with cotton cloth. Seat cushion in polyurethane foam with differentiated density T35 Eucalyptus and T30 SM covered with Dacron fibre 400 gr coupled with cotton cloth.

Cover: leather or fabric cover, completely removable.

Finishes: aluminium foot available in the following finishes: polished, satin-finished and painted in Brun Sablè, Black and White.

Composizione pagina 58-59 / Layout page 58-59

Divano letto Roger: rivestimento art. 1890/11. Piedini Grigio.

Materasso: 160x200x12h; rete: cm.182.

Roger sofa-bed: cover art. 1890/11. Greco feet.

Mattress: 160x200x12h; bedbase: cm.182.

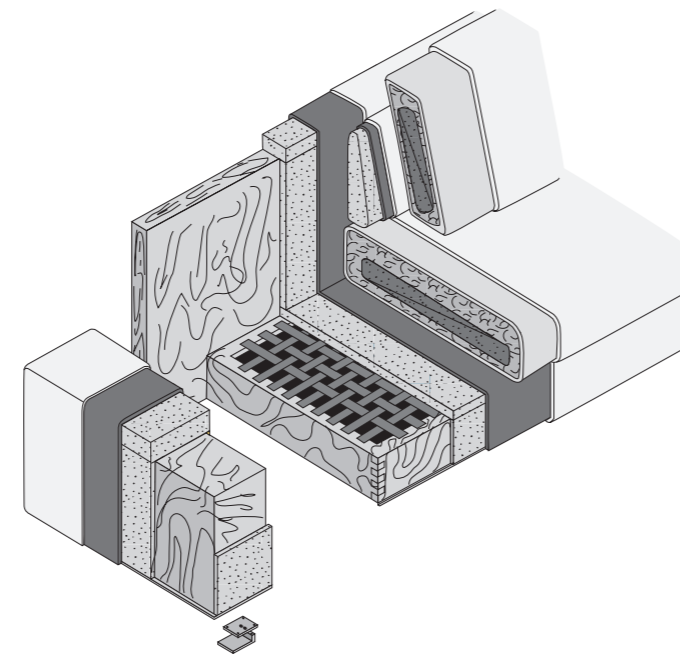
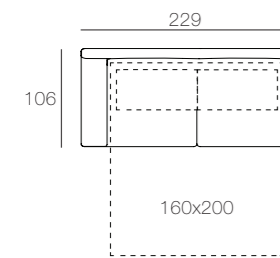

Composizione pagina 56-57 / Layout page 56-57

Divano Roger: rivestimento art. 1880/02; Piedini Nero.

Poltrona Vanity: rivestimento pelle accoppiata 4264/50 cat. Pelle accoppiata.

Tavolino allure cm. 50x50: basamento verniciato Nero con piano marmo Calacatta.

Roger sofa: cover art. 1880/02; Black feet.

Vanity armchair: coupled leather Cover 4264/50 cat. coupled leather.

Allure coffee table cm. 50x50: Black painted base with Calacatta marble top.

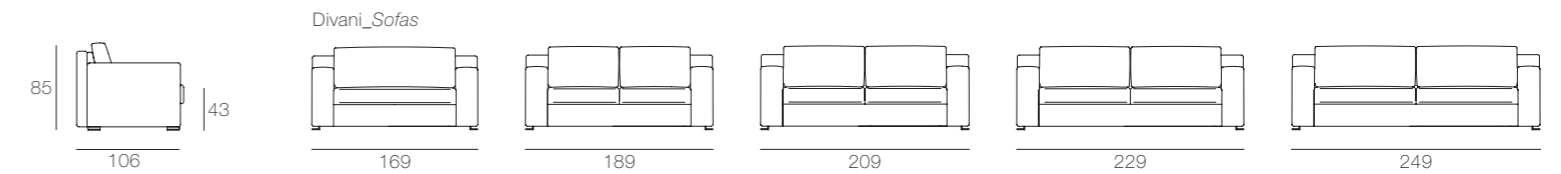
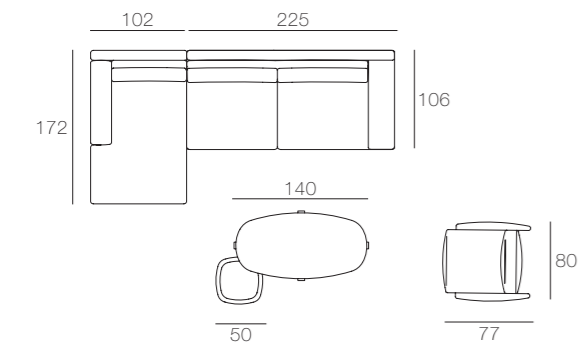

Divano bracciolo sx/dx_Sofas with 1 arm left/right

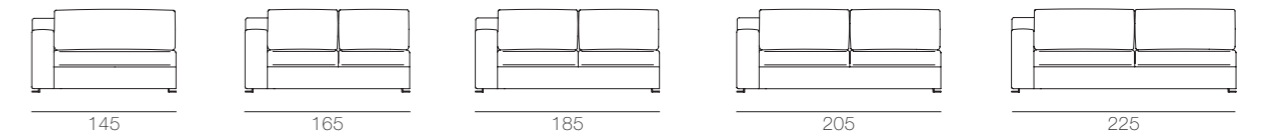

Poltrona bracciolo sx/dx Armchair with 1 arm left/right

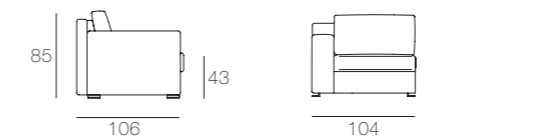

Elemento centrale poltrona Central element for armchair

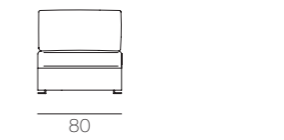

Letto_Bed

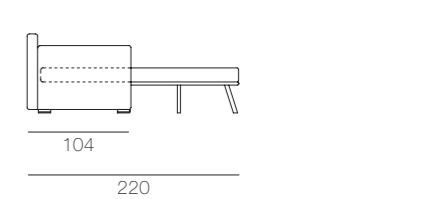

Elemento centrale fisso divano_Central fixed element for sofa
Elemento centrale fisso divano con letto_Central fixed element for bed-sofa

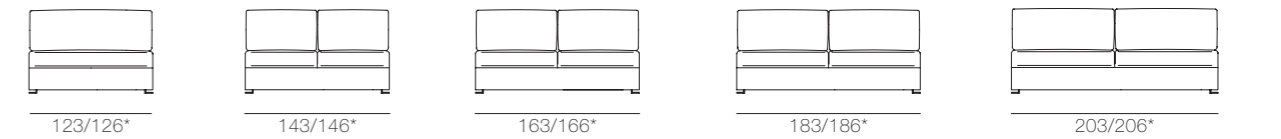

Chaise longue_Chaise longue

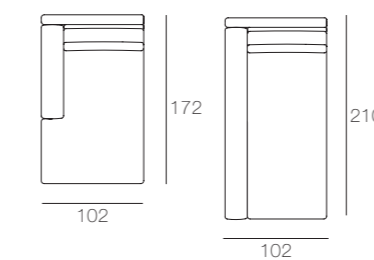

Angolo retto_Straight corner

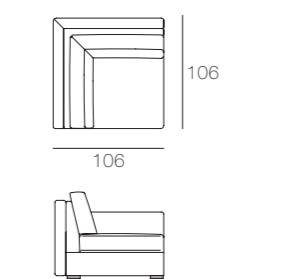

Pouff_Pouf

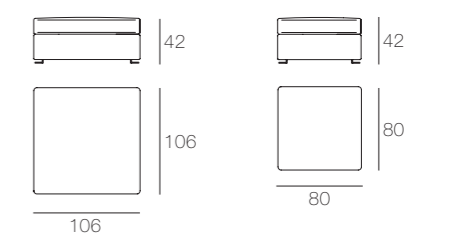

VARIANTI PIEDINI IN METALLO ALUMINIUM FEET OPTIONS



Alluminio lucido
Aluminium

Alluminio satinato
Satin aluminium

Verniciato Bianco
White painting

Verniciato Brun Sablè
Brun Sablè painting

Verniciato Nero
Black painting

ELLIOT

Design Marconato&Zappa

Caratteristiche: una collezione preziosa, con straordinarie possibilità arredative. Colpisce il morbido segno dei rombi con al centro il tipico bottone della lavorazione capitonné. Disponibile nella versione completamente imbottita o nella versione con basamento in legno di Frassino in sei varianti di finitura.

La progettazione ha considerato un valore importante la possibilità di un montaggio semplice, veloce e per un comodo trasporto.

Struttura: struttura basamento in Frassino. Telaio metallo verniciato.

Struttura in legno di abete. Molleggio ottenuto con cinghie elastiche Intes Elsbelt larghezza 60mm. Perni e viti per il montaggio.

Imbottitura della struttura: poliuretano espanso T35. Poliuretano espanso T40.

Imbottitura dei cuscini: cuscino seduta in piuma d'oca Oro, con inserto in poliuretano espanso a densità differenziata T30 SP e T35 SM rivestito in pelleo di cotone.

Rivestimento: rivestimento in pelle o in tessuto non sfoderabili.

Finiture basamento: basamento in legno di Frassino naturale, tinto Noce, tinto Noce scuro, tinto Wengè, in Frassino laccato Bianco o Nero poro aperto oppure completamente rivestito. Puntali ovali in alluminio lucido con feltrino.

Features: a truly fine collection, with extraordinary furnishing possibilities. Our eyes are drawn to the soft touch of the rhombuses with the typical button of the button-tufting workmanship in the centre. Available in the fully padded version or in the version with Ash wood base in six finish variants.

The design has considered an important value the possibility of a simple, fast assembly for a convenient transport.

Frame: Ash base frame. Painted metal frame.

Fir wood frame. Suspension support with elastic belts.

Intes Elsbelt width 60mm. Pins and screws for mounting.

Frame padding: T35 polyurethane foam. T40 polyurethane foam.

Cushion padding: Gold goose down seat cushion, with differentiated density polyurethane foam insert T30 SP and T35 SM covered in cotton muslin.

Cover: non-removable leather or fabric cover.

Base finishes: base in Ash wood with Natural finish, Walnut stain, dark Walnut stain, Wengè stain, in White or Black open-pore lacquered Ash or with complete cover. Oval polished aluminium tips with felt pad.

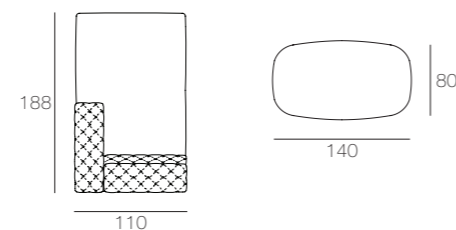
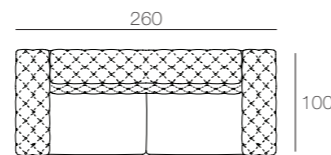
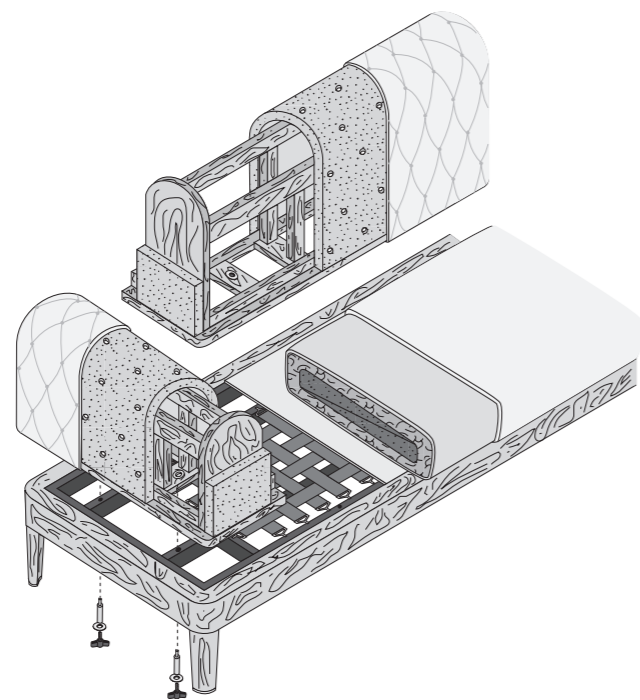

Composizione pagina 62-63 / Layout page 62-63

Divano Elliot: rivestimento art. 1470/2003, cat. Extralux. Basamento Frassino tinto Nero.

Chaise longue Elliot: rivestimento art. 1470/28 cat. Extralux. Basamento imbottito.

Tavolino Charme Ø140x40h: basamento verniciato Brun Sablè con piano in marmo Calacatta.

Elliot sofa: cover art. 1470/2003, cat. Extralux. Black stained Ash base.

Elliot chaise longue: cover art. 1470/28 cat. Extralux. Padded base.

Charme coffee table Ø140x40h: base painted in Brun Sablè with Calacatta marble top.

ELLIOT 692 BASAMENTO IMBOTTITO_COVERED BASE

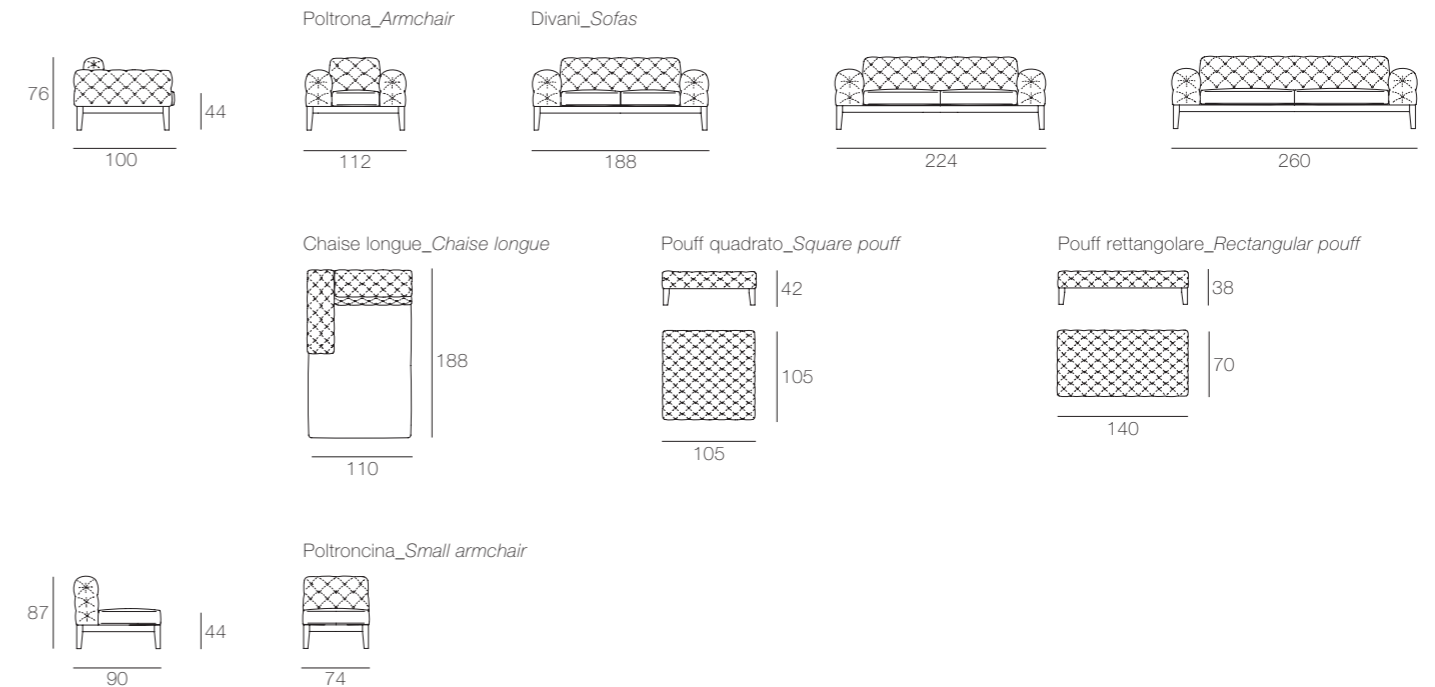

ELLIOT 691 BASAMENTO LEGNO_WOODEN BASE

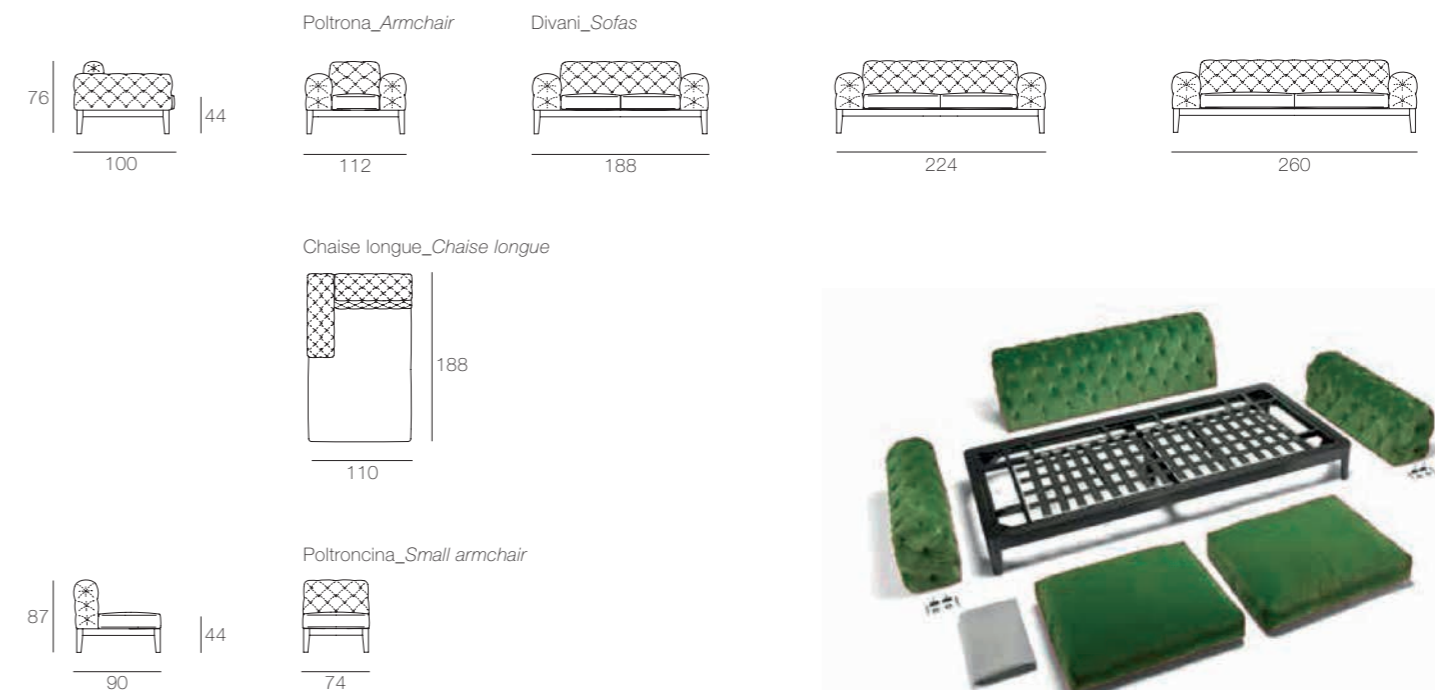

VARIANTI BASAMENTO IN LEGNO WOODEN BASE OPTIONS



GRACE

Struttura: realizzata in acciaio. Molleggio ottenuto con cinghie elastiche Intes Elsbelt 50mm.

Schienale e sedile: in poliuretano schiumato a freddo ignifugo. Vellutino accoppiato 3mm.

Rivestimento: in pelle o in tessuto non sfoderabile.

Basamento: in metallo cromato lucido girevole o fisso in legno di Frassino tinto naturale, Noce, Noce scuro, Wengè, Bianco e Nero.

Frame: steel. Suspension support with elastic straps Intes Elsbelt 50mm.

Backrest and seat: in fireproof cold-cured polyurethane foam. 3mm coupled velveteen.

Cover: in leather or non-removable fabric.

Base: polished chrome-plated swivel base or Ash wood fixed base with Natural, Walnut, dark Walnut or Wengè stain or White and Black.

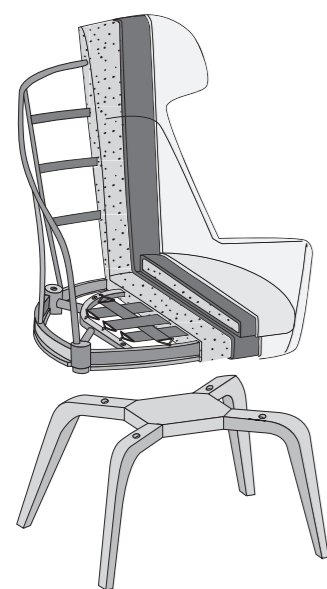

CON BASAMENTO IN LEGNO L10
WITH WOODEN BASE L10

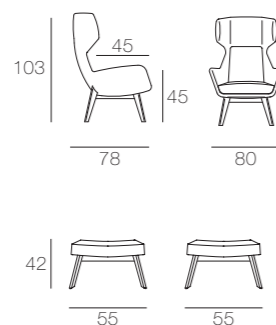

CON BASE METALLO P19
WITH P19 METAL BASE

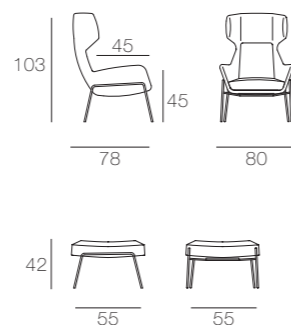

CON BASAMENTO GIREVOLE R13
WITH SWIVEL BASE R13

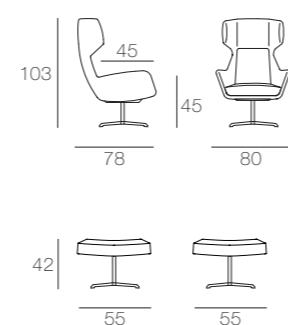

Composizione pagina 65 / Layout page 65

Poltrona Grace: rivestimento art. 1850/06, cat. VIP.

Basamento girevole verniciato Nero.

Tavolino For you: basamento verniciato Nero con piano marmo Calacatta.

Grace armchair: cover art. 1850/06, cat. VIP. Black painted swivel base.

For you coffee table: Black painted base with Calacatta marble top.

VARIANTI BASAMENTO FISSO IN LEGNO FIX WOODEN BASE OPTIONS



Frassino Naturale
Natural Ash

Frassino tinto Noce
Walnut stained Ash

Frassino tinto scuro
Dark stained Ash

Frassino Wengè
Wengè Ash

Frassino laccato
Nero poro aperto
Open-pore Black Ash

Cromato lucido
Glossy chrome

Verniciato Nero
Black painting

BASAMENTO GIREVOLE METALLO METAL SWIVEL BASE



VARIANTI BASAMENTO IN LEGNO WOODEN BASE OPTIONS



Frassino Naturale
Natural Ash

Frassino tinto Noce
Walnut stained Ash

Frassino tinto scuro
Dark stained Ash

Frassino Wengè
Wengè Ash

Frassino laccato
Nero poro aperto
Open-pore Black Ash

Frassino laccato
Bianco poro aperto
Open-pore white Ash

VANITY

Struttura: realizzata in acciaio. Molleggio ottenuto con cinghie elastiche Intes Elsbelt 50mm.

Schienale e sedile: in poliuretano schiumato a freddo ignifugo. Vellutino accoppiato 3mm.

Rivestimento: in pelle o in tessuto non sfoderabile.

Basamento: in metallo cromato lucido girevole o fisso in legno di Frassino tinto naturale, Noce, Noce scuro, Wengè, Bianco e Nero.

Frame: steel. Suspension support with elastic straps Intes Elsbelt 50mm.

Backrest and seat: in fireproof cold-cured polyurethane foam. 3mm coupled velveteen.

Cover: in leather or non-removable fabric.

Base: polished chrome-plated swivel base or Ash wood fixed base with Natural, Walnut, dark Walnut or Wengè stain or White and Black.

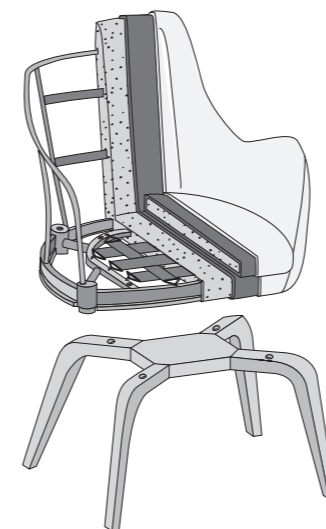

CON BASAMENTO IN LEGNO L10
WITH WOODEN BASE L10

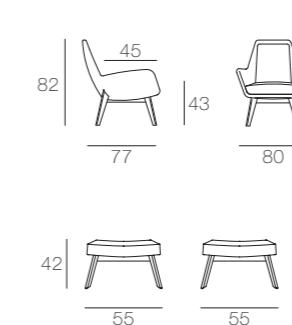

CON BASE METALLO P19
WITH P19 METAL BASE

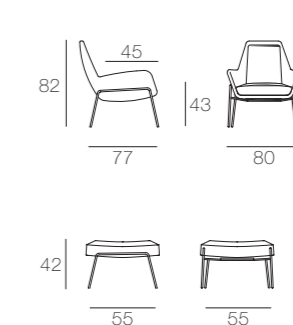

CON BASAMENTO GIREVOLE R13
WITH SWIVEL BASE R13

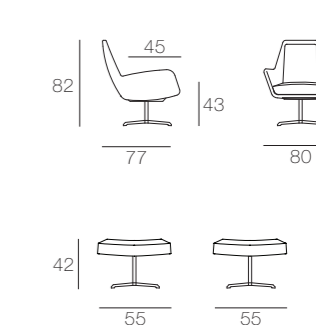

Composizione pagina 66-67 / Layout page 66-67

Poltrona Vanity: rivestimento pelle accoppiata 4264/50, cat. Pelle Accoppiata.

Basamento Frassino tinto Nero.

Tavolino allure cm. 50x50: basamento verniciato Nero con piano Brun Sablè.

Vanity armchair: leather Cover combined 4264/50, cat. coupled leather.

Allure coffee table: Black painted base with Brun Sablè top.

VARIANTI BASAMENTO FISSO IN LEGNO FIX WOODEN BASE OPTIONS



Frassino Naturale
Natural Ash

Frassino tinto Noce
Walnut stained Ash

Frassino tinto scuro
Dark stained Ash

Frassino Wengè
Wengè Ash

Frassino laccato
Nero poro aperto
Open-pore Black Ash

Cromato lucido
Glossy chrome

Verniciato Nero
Black painting

BASAMENTO GIREVOLE METALLO METAL SWIVEL BASE



VARIANTI BASAMENTO IN LEGNO WOODEN BASE OPTIONS

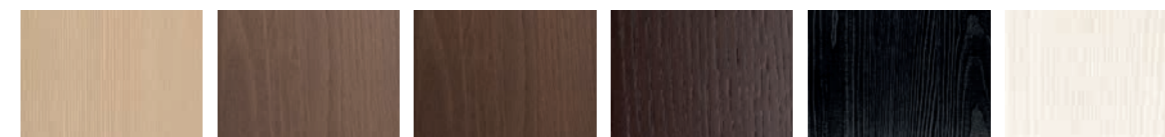

Frassino Naturale
Natural Ash

Frassino tinto Noce
Walnut stained Ash

Frassino tinto scuro
Dark stained Ash

Frassino Wengè
Wengè Ash

Frassino laccato
Nero poro aperto
Open-pore Black Ash

Frassino laccato
Bianco poro aperto
Open-pore white Ash

ARIEL

Struttura: realizzata in acciaio. Molleggio ottenuto con cinghie elastiche.
Schienale e sedile: in poliuretano schiumato a freddo ignifugo classe 1m. Vellutino accoppiato 3 mm.
Rivestimento: in pelle o in tessuto non sfoderabile.
Basamento: in metallo cromato o verniciato Nero opaco nella versione girevole o fisso in legno di Frassino tinto Nero, Noce, Noce scuro, Wengè o naturale.

Frame: steel. Suspension support with elastic straps.
Backrest and seat: in cold-cured polyurethane foam, class 1m fireproof. 3mm coupled velveteen.
Cover: in leather or non-removable fabric.
Base: chrome-plated or matt Black painted base in the swivel version, or fixed version in Black, Walnut, dark Walnut, Wengè or Natural stained Ash wood.

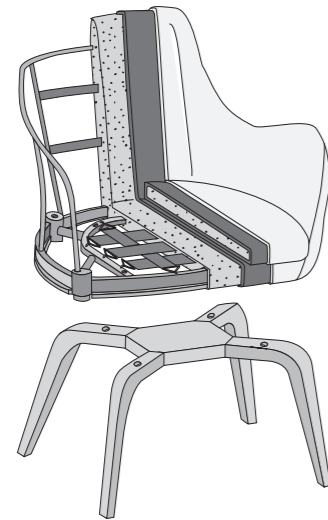

CON BASAMENTO IN LEGNO L10
WITH WOODEN BASE L10

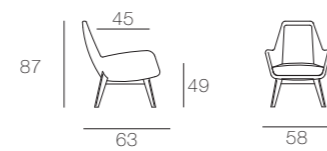

CON BASE METALLO P19
WITH P19 METAL BASE

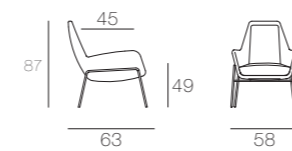

CON BASAMENTO GIREVOLE R13
WITH SWIVEL BASE R13

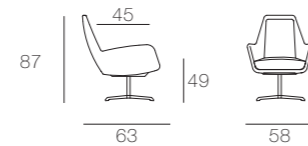

Composizione pagina 84 / Layout page 84

Poltrona Ariel: rivestimento art. 1880/12, cat. Extra. Basamento girevole verniciato Nero.
 Ariel armchair: cover art. 1880/12, cat. Extra. Black painted swivel base.

VARIANTI BASAMENTO FISSO IN LEGNO FIX WOODEN BASE OPTIONS



Frassino Naturale Natural Ash
 Frassino tinto Noce Walnut stained Ash
 Frassino tinto scuro Dark stained Ash
 Frassino Wengè Wengè Ash
 Frassino laccato Nero poro aperto Open-pore Black Ash
 Cromato lucido Glossy chrome
 Verniciato Nero Black painting

VARIANTI BASAMENTO IN LEGNO WOODEN BASE OPTIONS



Frassino Naturale Natural Ash
 Frassino tinto Noce Walnut stained Ash
 Frassino tinto scuro Dark stained Ash
 Frassino Wengè Wengè Ash
 Frassino laccato Nero poro aperto Open-pore Black Ash
 Frassino laccato Bianco poro aperto Open-pore white Ash

PLAZA

Design Marconato&Zappa

Struttura: realizzata in legno di Abete. Pannello in legno di multistrato curvato e molleggio ottenuto con cinghie elastiche Elasmat 790/4 larghezza 90mm.
Rivestimento struttura: in cuoietto, pelle o in tessuto.
Imbottitura: sedile in poliuretano espanso a densità differenziata T30 SPP e T3. Schienale in poliuretano a densità differenziata T21 SM e T40 P. Resinato 100gr. accoppiato con vellutino. Cuscinetto poggiatesta in piuma d'oca Oro.
Rivestimento: in pelle o in tessuto.
Piedini: realizzati in Frassino naturale o tinto Wengè, Noce, Noce scuro e laccato a poro aperto Bianco, Nero o rivestito in cuoietto o pelle.

Frame: fir wood panel. Curved multi-ply wood panel and elastic belt suspension (Elasmat 790/4 width 90mm).
Frame cover: in cuoietto leather, leather or fabric.
Padding: seat in differentiated density polyurethane foam (T30 SPP and T30). Back in differentiated density polyurethane (T21 SM and T40 P). Resin (100gr) coupled with velveteen. Lower back cushion in Oro goose down.
Cover: in leather or fabric.
Feet: in natural Ash wood or with Wengè, Walnut, dark Walnut stain and with white or Black open-pore lacquered or with cuoietto leather or leather cover.

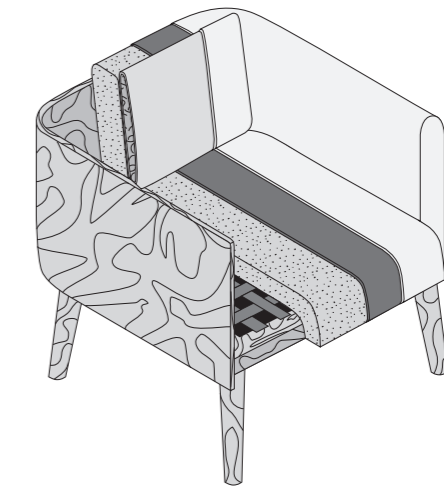
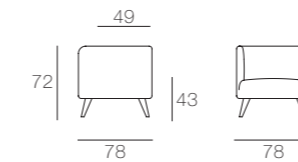

Composizione pagina 72-73 / Layout page 72-73

Poltrona Plaza: rivestimento art. 1810/04, cat. H; cuscino art. 1750/38, cat. H. Struttura scocca cuoietto Nero.
 Pouff Domino Ø50x38h: rivestimento art. 1770/08, cat. Extra.
 Pouff Domino Ø50x62h: rivestimento art. 1790/08, cat. Extra. Piano marmo Sahara Noir.
 Plaza armchair: cover art. 1810/04, cat. H; cushion art. 1750/38, cat. H.
 Black cuoietto leather body frame.
 Domino pouf Ø50x38h: cover art. 1770/08, cat. Extra.
 Domino pouf Ø50x62h: cover art. 1790/08, cat. Extra. Sahara Noir marble top.

VARIANTI STRUTTURA E PIEDINI IN CUIOETTO CUOJETTO LEATHER BASE AND FEET OPTIONS



VARIANTI PIEDINI IN LEGNO WOODEN FEET OPTIONS

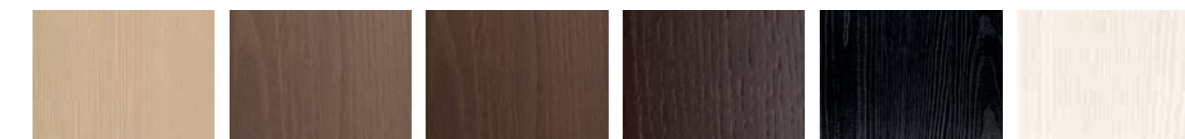

Frassino Naturale Natural Ash
 Frassino tinto Noce Walnut stained Ash
 Frassino tinto scuro Dark stained Ash
 Frassino Wengè Wengè Ash
 Frassino laccato Nero poro aperto Open-pore Black Ash
 Frassino laccato Bianco poro aperto Open-pore white Ash

MARGOT

Design Marconato&Zappa

Struttura: realizzata in legno di Abete e pannelli in legno multistrato curvato. Molleggio ottenuto con cinghie elastiche Intes Elasebelt 790/4 larghezza mm 90.

Schienale e sedile: in poliuretano espanso a densità differenziata T30 e T40. Poliuretano a densità differenziata T21 SM e T40 P. Resinato 100gr. accoppiato con vellutino. Cuscino poggiatesta T25 rivestito in fodera di cotone.

Rivestimento: tessuto completamente sfoderabile.

Basamento: la poltrona è disponibile in due versioni, con basamento o con piedini. I piedini in metallo disponibile nelle seguenti finiture: verniciato Oro, Brun Sablè, Nero, Grigio. Basamento in Frassino naturale o tinto Wengè, Noce, Noce scuro, laccato a poro aperto Bianco, e laccato a poro aperto Nero.

Frame: Fir wood and bent multi-ply panels. Elastic webbing suspension (90mm wide, Intes Elasebelt 790/4).

Backrest and seat: seat in differentiated density polyurethane foam (T30 and T40). Differentiated density polyurethane foam (T21 SM and T40 P). Resin (100gr) coupled with velveteen. Lower back cushion (T25) covered with cotton lining.

Cover: fully removable fabric.

Base: the sofa comes in two versions, with base or with feet.

Aluminium feet available in the following finishes: painted in satin Gold, Brun Sablè, Black and Grey. Base in Ash wood – Natural or Wengè, Walnut, dark Walnut stain and with white or Black open-pore lacquered.

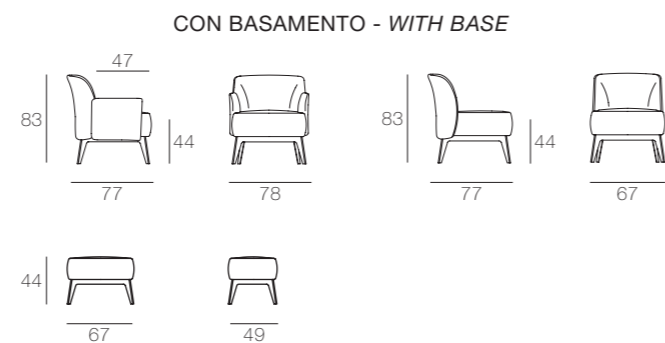
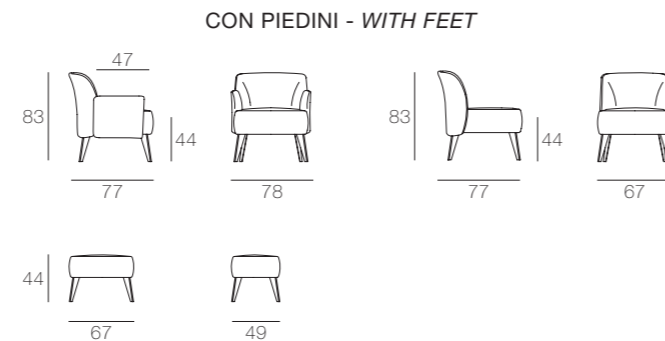
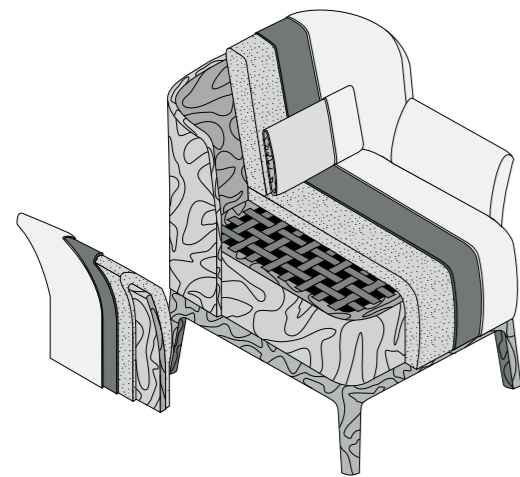

Composizione pagina 70-71 / Layout page 70-71

Poltrona Margot: rivestimento art.1690/07, cat. H
Struttura Frassino tinto Wengè.

Margot armchair: Cover art.1690/07, cat. H
Frame in Wengè stained Ash wood.

VARIANTI BASAMENTO IN LEGNO WOODEN BASE OPTIONS



Frassino Naturale Natural Ash
Frassino tinto Noce Walnut stained Ash
Frassino tinto scuro Dark stained Ash



Frassino Wengè Wengè Ash
Frassino laccato Nero poro aperto Open-pore Black Ash
Frassino laccato Bianco poro aperto Open-pore white Ash

VARIANTI PIEDINI IN METALLO ALUMINIUM FEET OPTIONS



Verniciato Oro Gold painting
Verniciato Brun Sablè Brun Sablè painting
Verniciato Nero Black painting
Verniciato Grigio Grey painting

JACK

Design Marconato&Zappa

Struttura: realizzata in legno massello di Frassino tinto o Noce Canaletto.

Finitura struttura: in legno Frassino tinto o laccato nei colori disponibili o Noce Canaletto.

Schienale e sedile: in poliuretano espanso a densità differenziata T40 e T25 rivestiti con resinato 150gr/mq accoppiato con vellutino con inserto in multistrato.

Rivestimento: in pelle, Nabuk o tessuto non sfoderabile.

Frame: stained solid Ash or Canaletto Walnut.

Frame finish: stained or lacquered Ash wood in the available colours or Canaletto Walnut.

Backrest and seat: T40 and T25 differentiated density polyurethane foam covered with 150gr/m2 resin coupled with velveteen with multi-ply insert.

Cover: not removable leather, Nubuck or fabric.

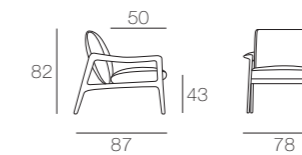

Composizione pagina 68 / Layout page 68

Poltrona Jack: rivestimento art. 1810/06, cat. H. Struttura Noce Canaletto.
Jack armchair: cover art. 1810/06, cat. H. Canaletto walnut frame.

Composizione pagina 69 / Layout page 69

Poltrona Jack: rivestimento art. 1850/13, cat. VIP. Struttura Frassino tinto Nero.
Jack armchair: cover art. 1850/13, cat. VIP Black stained Ash frame.

VARIANTI STRUTTURA IN LEGNO WOODEN FRAME OPTIONS



Frassino Naturale Natural Ash
Frassino tinto Noce Walnut stained Ash
Frassino tinto scuro Dark stained Ash
Frassino Wengè Wengè Ash
Frassino Nero Black Ash
Noce Canaletto Canaletto Walnut

GUEST

Design Marconato&Zappa

Struttura: realizzata in legno massello e multistrato curvato.

Rivestimento struttura: in legno Frassino tinto nei colori disponibili o Noce Canaletto.

Imbottitura: in poliuretano a densità differenziata T35 e T40 e rivestiti con resinato 150gr./mq accoppiato con vellutino.

Rivestimento: in pelle, Nabuk o tessuto, non sfoderabile.

Frame: stained solid Ash or Canaletto Walnut and bent multi-ply.

Frame finish: stained or lacquered Ash wood in the available colours or Canaletto Walnut.

Backrest and seat: T35 and T40 differentiated density polyurethane foam covered with 150gr/m2 resin coupled with velveteen.

Cover: not removable leather, Nubuck or fabric.

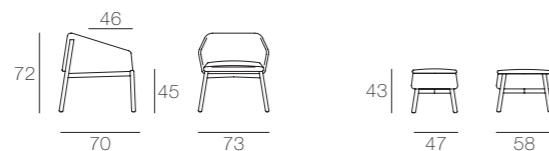

Composizione pagina 74-75 / Layout page 74-75

Poltrona e pouff Guest: rivestimento pelle accoppiata art.4264/45 gr. Struttura Frassino Wengè.
Guest armchair and pouf: cover in split leather art.4264/45 gr. Wengè Ash frame.

VARIANTI STRUTTURA IN LEGNO WOODEN FRAME OPTIONS



Frassino Naturale
Natural Ash

Frassino tinto Noce
Walnut stained Ash

Frassino tinto scuro
Dark stained Ash

Frassino Wengè
Wengè Ash

Frassino Nero
Black Ash

Noce Canaletto
Canaletto Walnut

ALLURE

Design Marconato&Zappa

Struttura: realizzata in metallo in 3 finiture: verniciato Brun Sablè, verniciato Nero opaco, verniciato Oro, con appoggio a terra su puntali con materiale termoplastico.

Piano superiore: disponibile in marmo Calacatta, Emperador, Sahara Noir.

Frame: made of metal in 3 finishes: Brun Sablè painted, matt Black painted, Gold painted, with ground support on tips with thermoplastic material.

Upper top: available in Calacatta, Emperador and Sahara Noir marble.

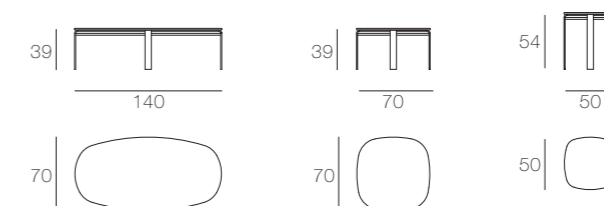

Composizione pagina 76 / Layout page 76

Tavolino Allure cm. 70x70: Basamento verniciato Nero con piano marmo Calacatta.
Allure coffee table cm. 70x70: Black painted base with Calacatta marble top.

Composizione pagina 77 / Layout page 77

Tavolino Allure cm. 50x50: Basamento verniciato Brun Sablè con piano marmo Calacatta.
Tavolino Allure cm. 140x70: Basamento verniciato Brun Sablè con piano marmo Sahara Noir.
Allure coffee table cm. 50x50: Brun Sablè painted base with Calacatta marble top.
Allure coffee table cm. 140x70: Brun Sablè painted base with Sahara Noir marble top.

VARIANTI STRUTTURA IN METALLO ALUMINIUM STRUCTURE OPTIONS



Verniciato Oro
Gold painting

Verniciato Brun Sablè
Brun Sablè painting

Verniciato Nero
Black painting

VARIANTI PIANO IN MARMO MARBLE TOP OPTIONS

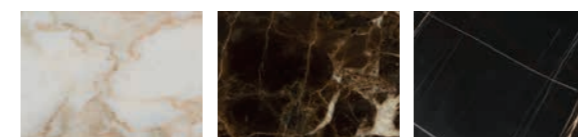

Calacatta
Calacatta

Emperador
Emperador

Sahara Noir
Sahara noir

FOR YOU

Design Marconato&Zappa

Struttura: realizzata in metallo in 3 finiture: verniciato brun sable, verniciato Nero opaco, verniciato Oro, con appoggio a terra su puntali con materiale termoplastico.

Piano superiore: disponibile in marmo Calacatta, Emperador, Sahara Noir e in Cuoietto.

Frame: metal in 3 finishes: brun sable, matt Black and Gold paint, with ground support on tips with thermoplastic material.

Upper top: available in Calacatta Emperador and Sahara noir marble, or in Cuoietto leather.

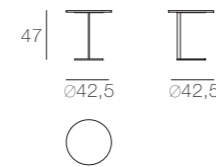

Composizione pagina 79 / Layout page 79

Tavolino For you: basamento verniciato Nero con piano marmo Calacatta.
For you coffee table: Black painted base with Calacatta marble top.

VARIANTI STRUTTURA IN METALLO ALUMINIUM STRUCTURE OPTIONS



Verniciato Oro
Gold painting

Verniciato Brun Sablè
Brun Sablè painting

Verniciato Nero
Black painting

VARIANTI PIANO IN MARMO MARBLE TOP OPTIONS

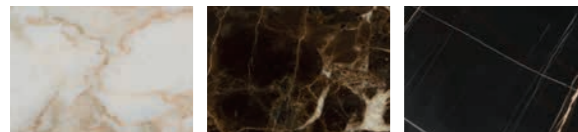

Calacatta
Calacatta

Emperador
Emperador

Sahara Noir
Sahara noir

VARIANTI STRUTTURA E PIEDINI IN CUIOETTO CUIOETTO LEATHER BASE AND FEET OPTIONS



Bianco
White

Sabbia
Sand

Tortora
Dove-Grey

Coloniale
Colonial

Naturale
Natural

Bordeaux chiaro
Light burgandy red



Verde bosco
Forrest green



Blu scuro
Dark blue



Testa di moro
Dark brown



Grigio
Grey



Nero
Black

TAPE

Design Marconato&Zappa

Struttura: realizzata in legno massello curvato di Frassino tinto nei colori disponibili o Noce Canaletto.

Piano: realizzato in marmo Calacatta, Emperador, Portoro o Sahara noir od in gres porcellanato finitura Calacatta o Nero Marquinia.

Frame: curved solid Ash wood stained in the available colours or Canaletto Walnut.

Top: Calacatta, Emperador, Portoro or Sahara Noir marble, or in porcelain stoneware with Calacatta or Marquinia Black finish.

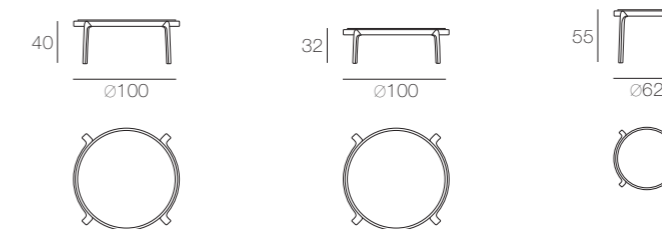

Composizione pagina 82 / Layout page 82

Tavolino Tape Ø100x32h: struttura in Frassino tinto Nero con piano marmo Calacatta.
Tavolino Tape Ø100x40h: struttura in Frassino tinto Nero con piano marmo Sahara Noir.
Tavolino Tape Ø62x55h: struttura in Frassino tinto Nero con piano marmo Calacatta.
Tape coffee table Ø100x32h: Black stained Ash frame with Calacatta marble top.
Tape coffee table Ø100x40h: Black stained Ash frame with Sahara Noir marble top.
Tape coffee table Ø62x55h: Black stained Ash frame with Calacatta marble top.

VARIANTI STRUTTURA IN LEGNO WOODEN FRAME OPTIONS

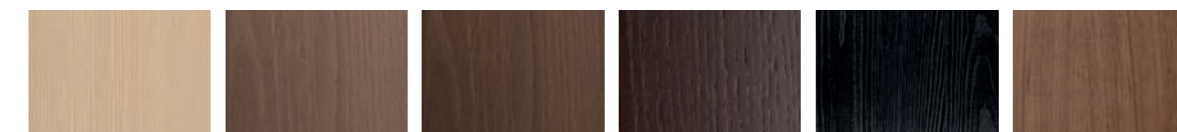

Frassino Naturale
Natural Ash

Frassino tinto Noce
Walnut stained Ash

Frassino tinto scuro
Dark stained Ash

Frassino Wengè
Wengè Ash

Frassino Nero
Black Ash

Noce Canaletto
Canaletto Walnut

VARIANTI PIANO IN MARMO MARBLE TOP OPTIONS

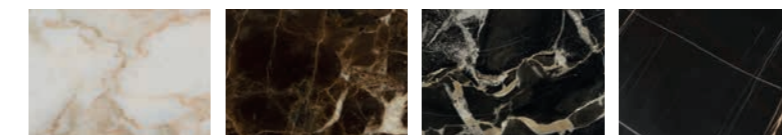

Calacatta
Calacatta

Emperador
Emperador

Nero Portoro
Portoro Black

Sahara Noir
Sahara noir

VARIANTI PIANO IN GRES PORCELLANATO PORCELAIN STONEWARE TOP OPTIONS



Calacatta
Calacatta

Nero Marquinia
Marquinia Black

CHARME

Design Marconato&Zappa

Struttura: realizzata in metallo in due finiture: verniciato bronzo scuro anodizzato e verniciato Oro.

Piano superiore: disponibile in marmo Calacatta, Emperador, Portoro, Sahara Noir e in legno impiallacciato Frassino tinto.

Frame: metal base in two finishes - painted dark bronze anodized and painted Gold satin finish.

Upper top: available in Calacatta marble, Emperador marble, Portoro marble, Sahara Noir marble and painted Ash veneer.

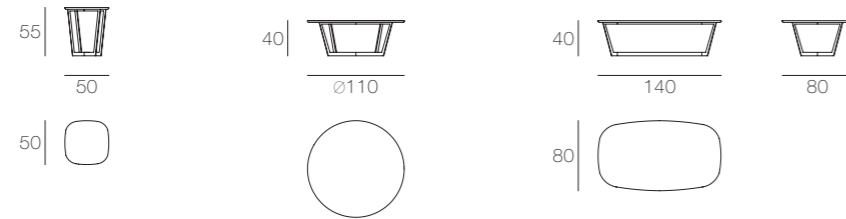

VARIANTI BASAMENTO BASE OPTIONS



Verniciato bronzo scuro anodizzato
Anodized dark bronze paint

Verniciato Oro
Gold painted

VARIANTI PIANO IN MARMO MARBLE TOP OPTIONS

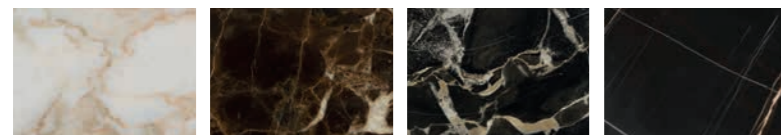

Calacatta
Calacatta

Emperador
Emperador

Nero Portoro
Portoro Black

Sahara Noir
Sahara noir

VARIANTI PIANO IN LEGNO WOODEN TOP OPTIONS



Frassino Naturale
Natural Ash

Frassino tinto Noce
Walnut stained Ash

Frassino tinto scuro
Dark stained Ash

Frassino Wengè
Wengè Ash

Frassino laccato Nero poro aperto
Open-pore Black Ash

Frassino laccato Bianco poro aperto
Open-pore white Ash

DOMINO

Design UT. CTS salotti

Struttura: realizzata in multistrato di Abete.

Imbottitura: in poliuretano espanso.

Rivestimento: in pelle, Nabuk o tessuto non sfoderabile.

Il pouff domino è disponibile in quattro versioni con e senza basamento e con piano superiore o senza.

Basamento: realizzato in legno Faggio tinto o laccato nei colori disponibili.

Piano superiore: realizzato in gres porcellanato finitura Calacatta o Nero Marquinia.

Frame: fir multi-ply.

Padding: polyurethane foam

Cover: not removable leather, Nubuck or fabric.

The domino pouf is available in four versions with and without base and with or without top.

Base: stained or lacquered beech wood in the available colours.

Upper top: available in Calacatta or Marquinia Black porcelain stoneware.

CON PIEDINI - WITH FEET

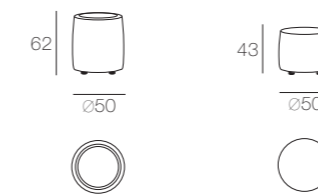

CON BASAMENTO - WITH BASE

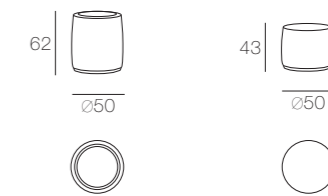

VARIANTI PIEDINI IN LEGNO WOODEN FEET OPTIONS



Faggio Naturale
Natural beech

Faggio tinto Noce
Walnut stained beech

Faggio tinto scuro
Dark stained beech

Faggio Wengè
Wengè beech

Faggio Nero
Black beech

VARIANTI PIEDINI LACCATO LACQUERED FEET OPTIONS



Laccato bronzo
Bronze lacquer

VARIANTI BASAMENTO IN LEGNO WOODEN BASE OPTIONS

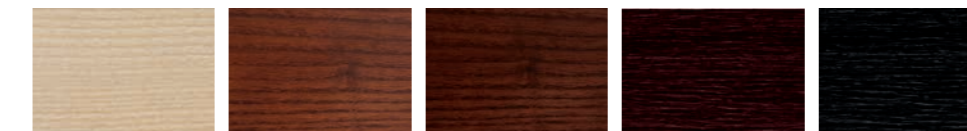

Faggio Naturale
Natural beech

Faggio tinto Noce
Walnut stained beech

Faggio tinto scuro
Dark stained beech

Faggio Wengè
Wengè beech

Faggio Nero
Black beech

VARIANTI BASAMENTO LACCATO LACQUERED BASE OPTIONS

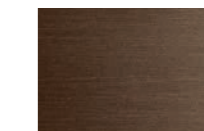

Laccato bronzo
Bronze lacquer

VARIANTI PIANO IN MARMO MARBLE TOP OPTIONS

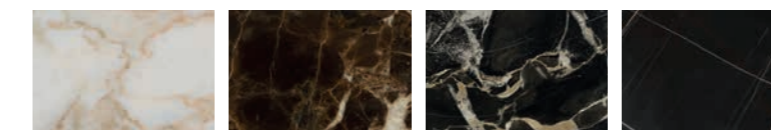

Calacatta
Calacatta

Emperador
Emperador

Nero Portoro
Portoro Black

Sahara Noir
Sahara noir

VARIANTI PIANO IN GRES PORCELLANATO PORCELAIN STONEWARE TOP OPTIONS



Calacatta
Calacatta

Nero Marquinia
Marquinia Black

BRERA

Design Marconato&Zappa

Struttura: realizzata in multistrato di Abete.

Imbottitura: in poliuretano espanso a densità differenziate PF 30 e T 40 e tela di cotone 150 gr con vellutino.

Rivestimento: in pelle o in tessuto sfoderabile.

Finiture: piedini in abs Nero.

Frame: multi-ply Fir.

Padding: in polyurethane foam with differentiated densities PF 30 and T 40 and 150 gr cotton cloth with velveteen.

Cover: leather or removable fabric.

Finishes: feet in Black abs.

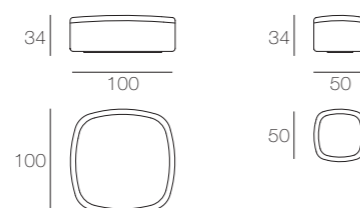

Composizione pagina 80 / Layout page 80

Pouff Brera 100x100h: rivestimento art. 1830/13, cat. Extralux; cuscino decorativo art. 1860/500, cat. Extralux; cuscino domeuse Ikon art. 4263/18, cat. Extra. Piedini Abs Nero.

Brera pouf 100x100h: cover art. 1830/13, cat. Extralux; decorative cushion art. 1860/500, cat. Extralux; Ikon daybed cushion art. 4263/18, cat. Extra. Feet in Black abs.

Composizione pagina 81 / Layout page 81

Pouff Brera 100x100h: rivestimento art. 1830/13, cat. Extralux. Piedini abs Nero.
Pouff Brera 50x50h: rivestimento art. 1830/01, cat. Extralux. Piedini abs Nero.
Pouff bracciolo Ikon 45x99h: rivestimento art. 1830/02, cat. Extralux. Piedini abs Nero.

*Brera pouf 100x100h: cover art. 1830/13, cat. Extralux. Feet in Black abs.
Brera pouf 50x50h: cover art. 1830/01, cat. Extralux. Feet in Black abs.
Ikon armrest pouf 45x99h: cover art. 1830/02, cat. Extralux. Feet in Black abs.*

VARIANTI PIEDINI IN ABS ABS FEET OPTIONS



Verniciato Nero
Black painting

Data la nostra politica aziendale di continua implementazione e miglioramento dei nostri prodotti, le dimensioni e le caratteristiche tecniche degli stessi potrebbero variare in qualsiasi momento, secondo le esigenze tecnico e commerciali, e ciò senza l'obbligo di preavviso e senza possibilità di rivendicazione da parte dell'acquirente.

Le illustrazioni, i dati e le descrizioni contenuti in questo catalogo non sono quindi impegnativi ed hanno solo valore indicativo.

La tecnica di stampa può determinare differenze di colore. Per una corretta valutazione di tonalità e colore è necessario fare riferimento ai campioni fisici. In ogni caso, i materiali quali metalli, tessuti, pelli, marmi ed essenze possono essere oggetto di naturali ed inevitabili differenze di tonalità e di venatura rispetto al campione fisico.

Nessuna parte di questo catalogo, testo o fotografia può essere riprodotta o trasmessa in qualsiasi forma o tramite mezzo elettronico o meccanico, comprese le fotocopie, senza previo permesso scritto da parte della società CTS SALOTTI.

Due to the company policy of continuous implementation and improvement of our product, dimensions and technical characteristics may vary at any time, according to technical and commercial requirements. These variations may occur without obligation of warning and without the possibility of claim by the buyer. The illustrations, data and descriptions contained in this catalogue are therefore to be considered as an indication of the final products.

Printing methods can determine colour differences. For a correct evaluation of tone and colour it is necessary to refer to the physical samples. In any case, materials such as metal, fabrics, leather, marble and wood may be subject to natural and inevitable differences in tone and grain compared to the physical sample.

No part of this catalogue, text or photograph may be reproduced or transmitted in any shape or form, through electronic or paper-based communication, including photocopies, without the prior express written consent of CTS SALOTTI.

Credits:

AD: Galvani&Tremolada

Ph: Master Fotografie

Stylist: Francesca Sassi

Print: Grafiche Boffi

Si ringrazia:

SIRECOM TAPPETI ITALIA

CONTARDI LIGHTING

CTS
ITALIAN SOFAS

Via Ada Negri, 5_Carate Brianza (MB)
Italy +39 0362 991038
info@ctssalotti.com_www.ctssalotti.com

